

Programma completo
Produktübersicht
Product overview

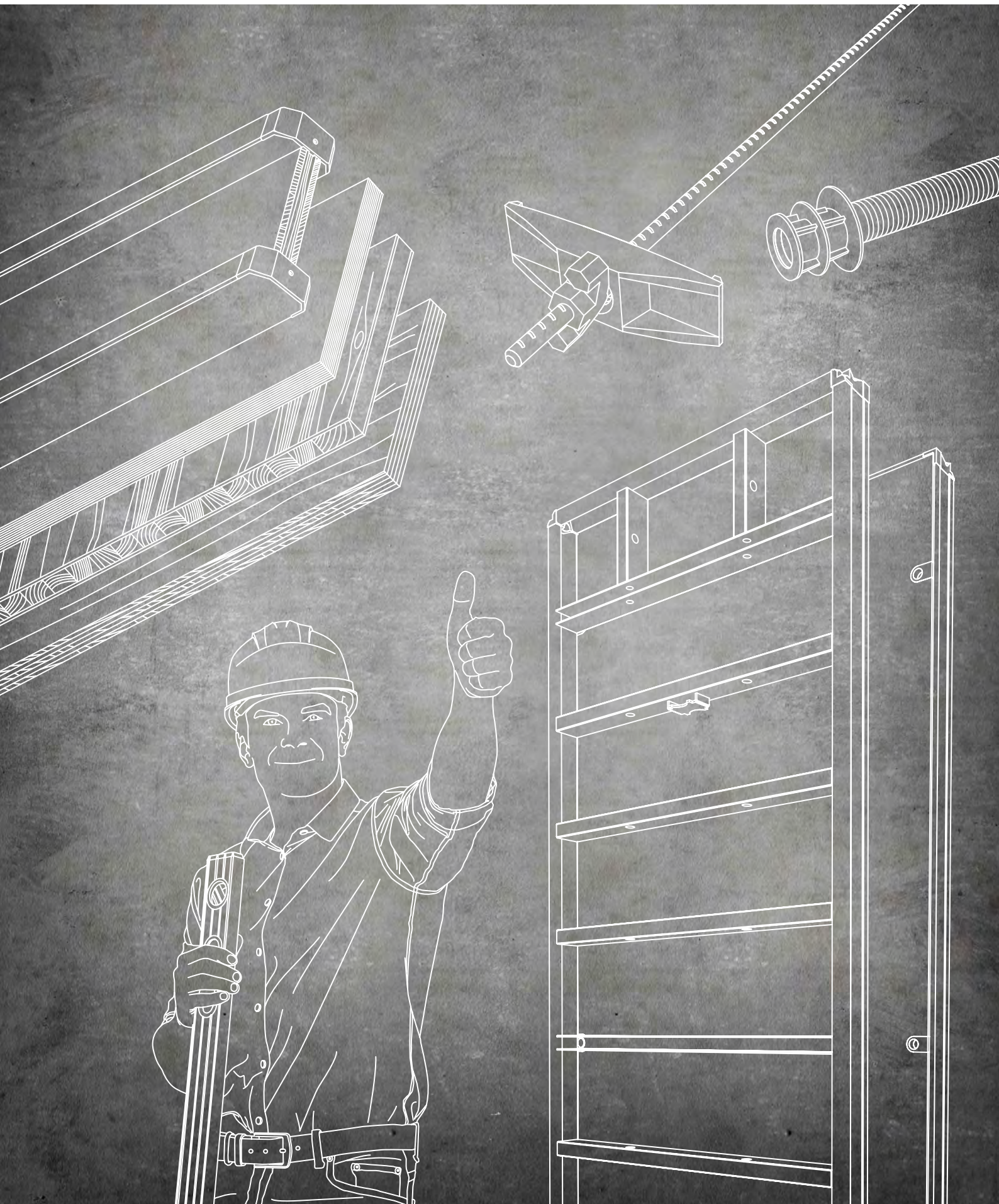

Cemento in forma
Alles in Schalung
All for formwork



Cemento in forma

Questa è la nostra offerta per voi. "Tutto" ha inizio con una consulenza competente da parte dei nostri specialisti di casseforme, prosegue con i prodotti del nostro vasto assortimento e comprende anche il supporto del nostro consolidato programma di assistenza: gettiamo così le basi affinché i nostri clienti possano portare a termine ogni attività di cassetteria all'insegna dell'efficienza e della sicurezza.

Alles in Schalung

Das ist unser Angebot an Sie. „Alles“ beginnt mit der kompetenten Beratung unserer Schalungsspezialisten. „Alles“ setzt sich weiter mit den Produkten aus unserem umfassenden Produktsortiment fort und „alles“ schließt auch die Unterstützung durch unser ausgereiftes Serviceprogramm mit ein. So sind alle Voraussetzungen gegeben, dass unsere Kunden effizienter und sicherer schalen.

All for formworks

This is our offer to you. "Everything" begins with the expert advice of our formwork specialists. "Everything" continues with the products from our comprehensive range: "everything" also includes the support of our advanced service programme. Every condition is thus met to ensure more efficient and safer forming for our customers.



Indice

Inhaltsverzeichnis

Index

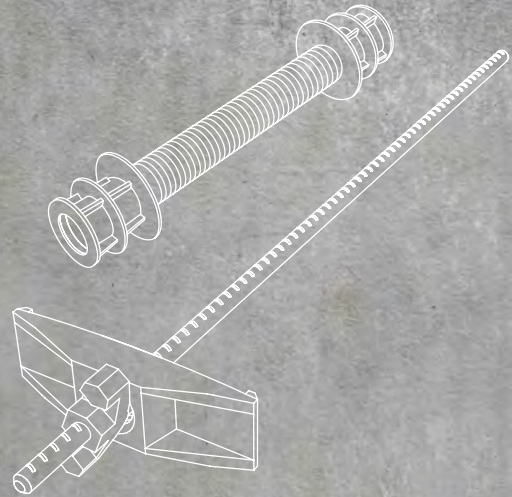
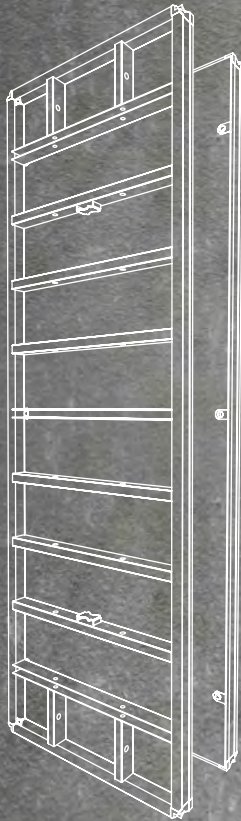

Sistema casseforme **Systemschalung** **Concrete formwork system**

06

PANAWALL Cassero a telaio
PANAWALL Rahmenschalung
PANAWALL Framed formwork

PANADECK Cassaforma per solaio
PANADECK Deckenschalung
PANADECK slab formwork

PAX Cassaforma per pilastri
PAX Stützenschalung
PAX Formwork for pillars

PANAVELOX Sistema cassero in legno
PANAVELOX Holzschalungssystem
PANAVELOX Wooden formwork system

Accessori per casseforme **Schalungszubehör** **Formwork accessories**

14

Distanziatori & Accessori
Abstandshalter & Zusatzteile
Spacers & fittings

Sistemi d'armatura
Bewehrungssysteme
Reinforcement systems

Impermeabilizzazioni
Bauwerksabdichtungen
Structural waterproofing

Sistemi di cassetta
Schalungstechnik
Formwork accessories

Morsetti
Schalungsklemmen
Formwork clamps

Barre e accessori
Schalungsanker & Zubehör
Formwork anchor & accessories

Giunti per ponteggi
Gerüstkupplungen
Scaffolding couplers

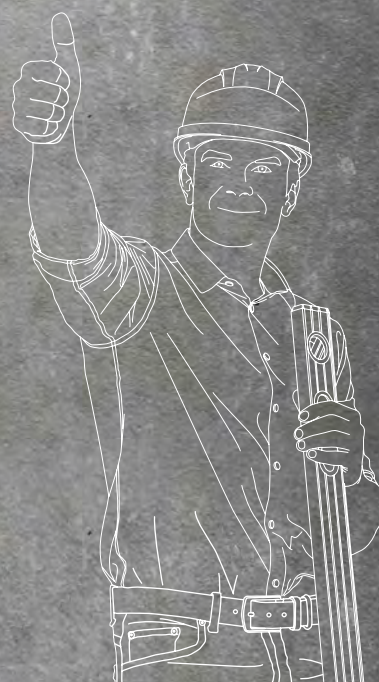
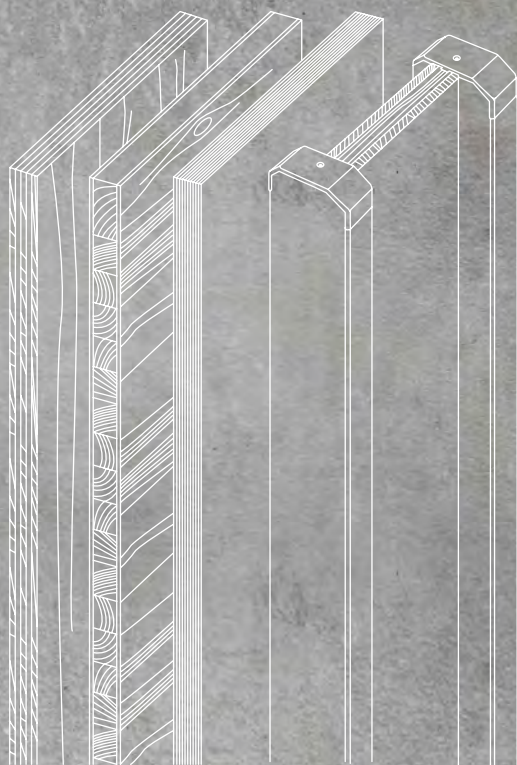

Prodotti in legno
Holzprodukte
Timber products

26

Multistrato filmato
 Sperrholz befilmt
 Filmfaced plywood

Multistrato grezzo
 Sperrholz roh
 Raw plywood

Pannelli per casseforme
 Holzschalungsplatten
 Shuttering panels

Trave per casseforme
 Holzschalungsträger
 Concrete formwork beams

Servizio
Service
Service

32

Noleggio casseforme & progettazione
 Schalungsmiete & Planung
 Formwork rental & planning

Logistica
 Logistik
 Logistics

Ripristino casseforme
 Schalungsrenovierung
 Formwork renewal

Lavorazione pannelli
 Plattenzuschnitt
 Machined panels

Sistema casseforme | Systemschalung | Concrete formwork system

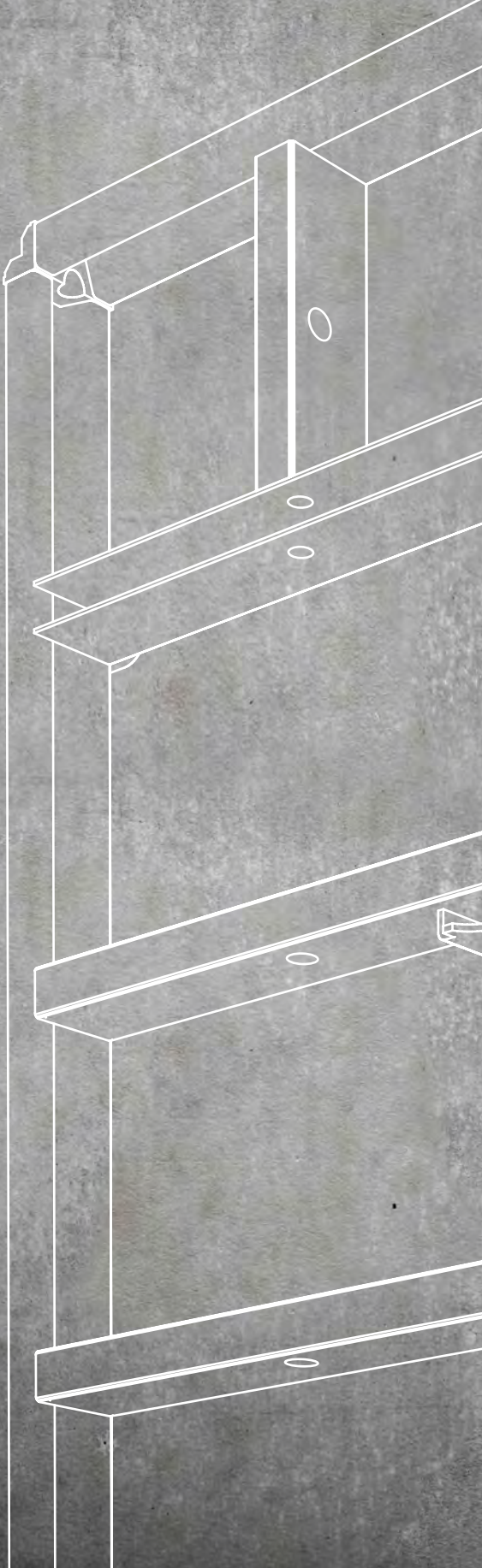

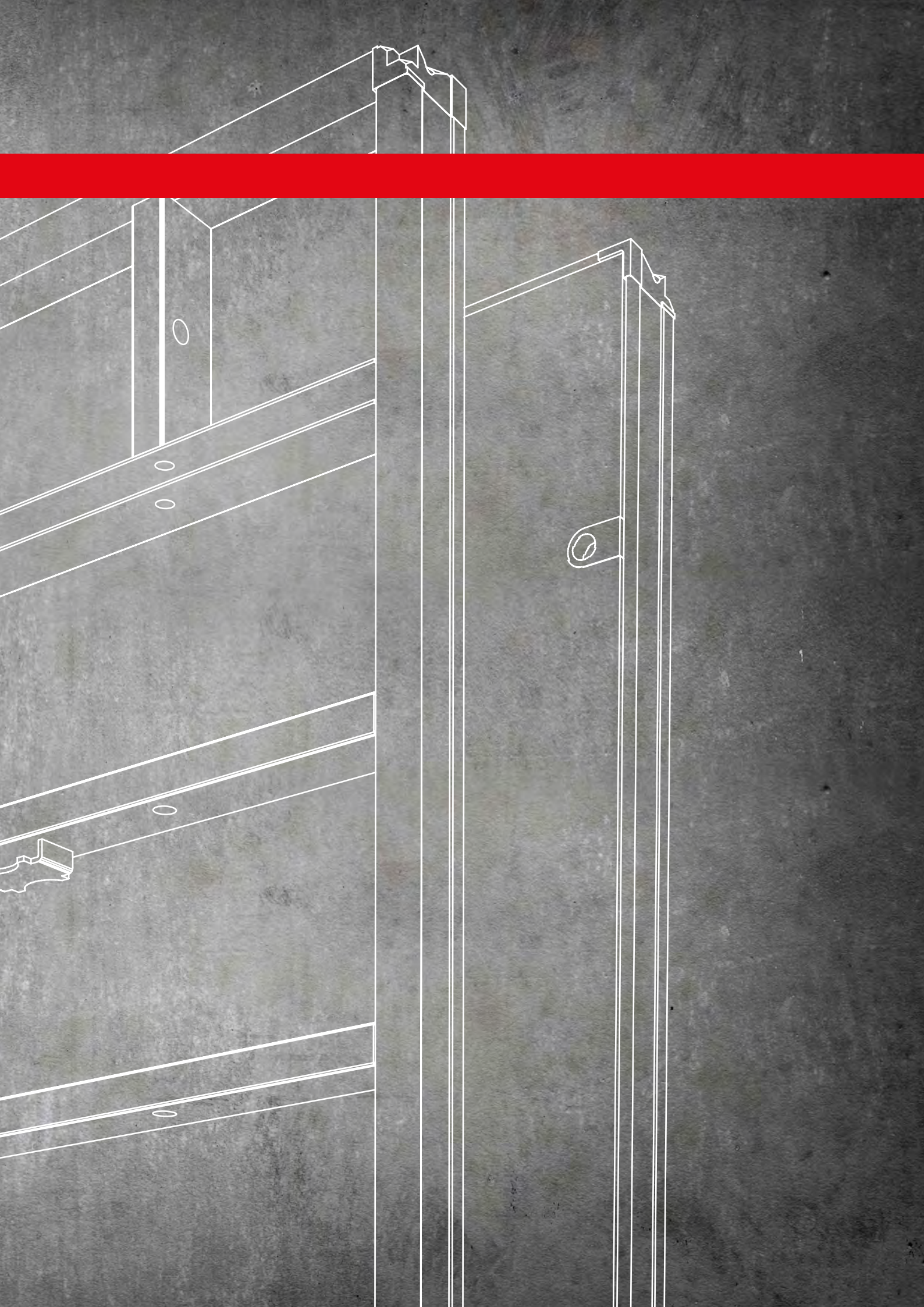

PANAWALL Casseforme a telaio di ottima qualità

Con PANAWALL e PANAWALL PLUS di PANALEX, disporrete del sistema ideale per far fronte a ogni sfida ed esigenza costruttiva. Un solido telaio in acciaio con speciale profilo perimetrale consente una semplice applicazione delle morse, con un'efficiente funzione di allineamento e collegamento.

PANAWALL Rahmenschalungen in Top-Qualität

Mit PANAWALL und PANAWALL PLUS von PANALEX erwerben Sie das ideale Schalensystem für Ihre An- und Herausforderungen am Bau. Ein starker Stahlrahmen mit umlaufendem Spezialprofil ermöglicht das einfache Anbringen des effizient ausrichtenden und verbindenden Keilschlusses.

PANAWALL Top-quality framed formwork

PANAWALL and PANAWALL PLUS from PANALEX offer you the ideal formwork system for every type of construction challenge. A strong steel frame with a surrounding special profile permits easy attachment of the clamp for effective alignment and connection.

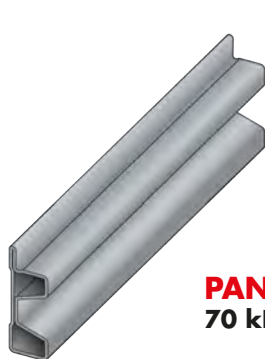

PANAWALL (PW)
70 kN/m²



PANAWALL PLUS (PWP)
90 kN/m²

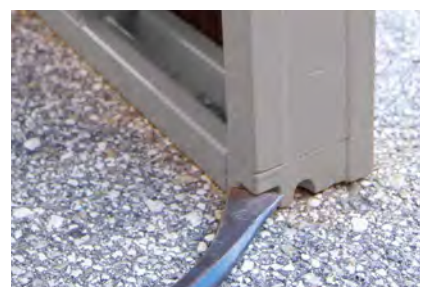

PANAWALL Pannelli
PANAWALL Elemente
PANAWALL Elements



Angoli-Compensi
Ecken-Ausgleiche
Corner-Compensations

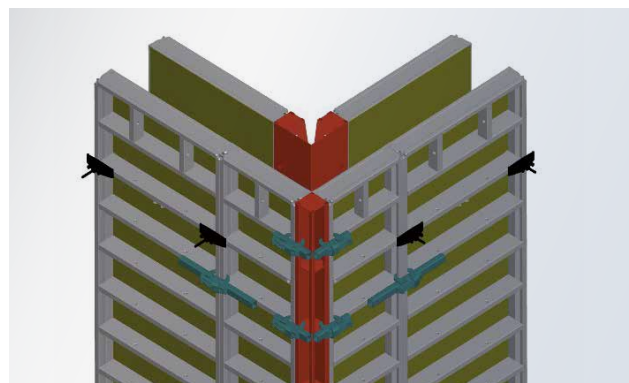

Accessori di collegamento
Verbindungszubehör
Connecting parts

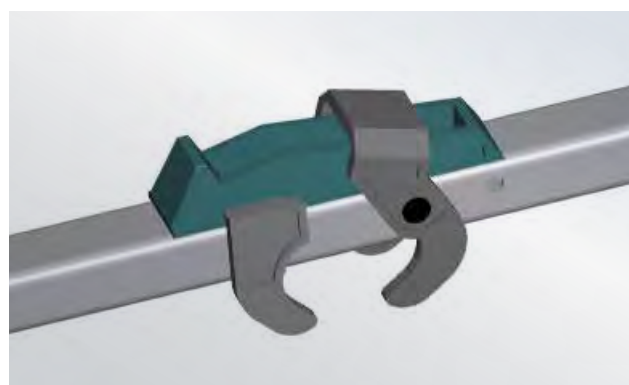

Sicurezza e trasporto
Sicherheit und Transport
Safety and transport



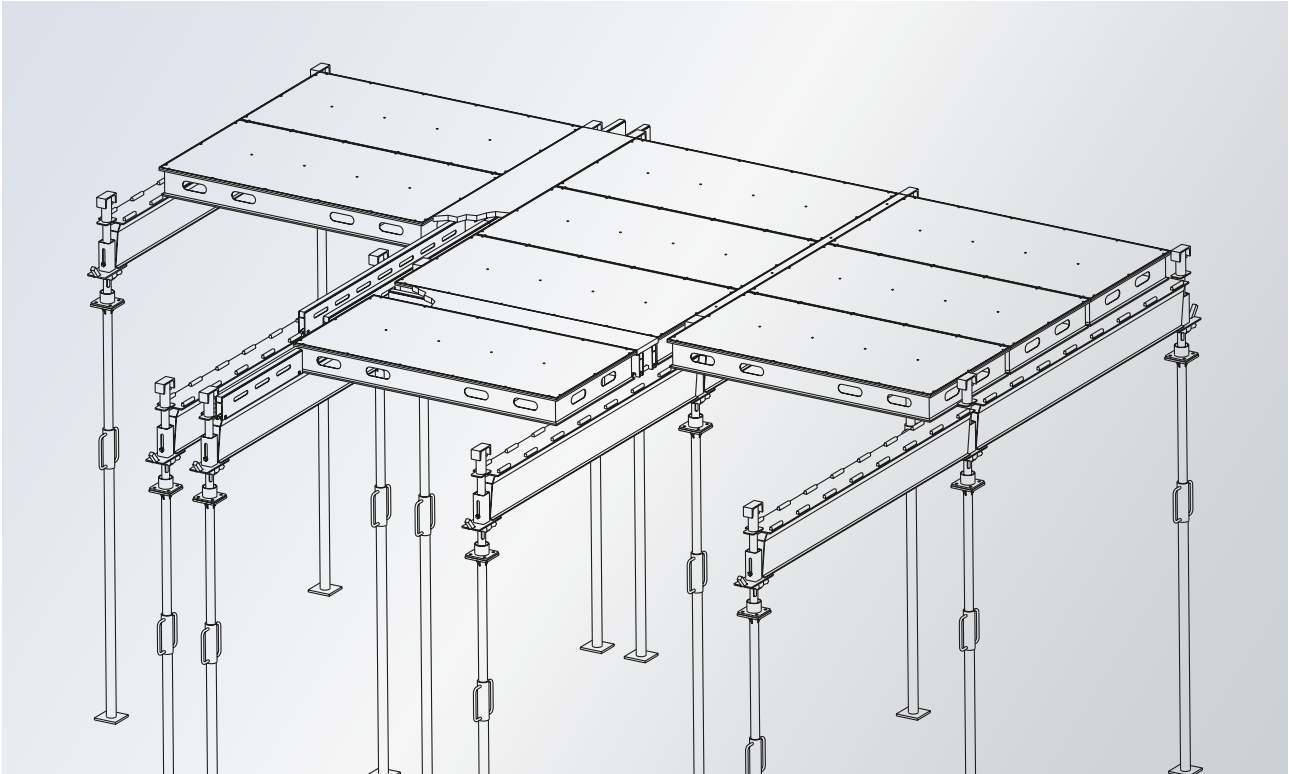

NOVITÀ

PANADECK – 1 solo sistema per 2 metodi di cassaforma

La cassaforma per solai che si adatta a ogni altezza e planimetria.

NEUHEIT

PANADECK – 1 System für 2 Schalmethoden

Die Deckenschalung, die für alle Grundrisse und Höhen passt.

NEWS

PANADECK – 1 system for 2 formwork methods

Ceiling formwork suitable for all floor plans and elevations.



PAX – CASSAFORMA PER PILASTRI

Il sistema di cassaforma per pilastri versatile.

PAX – PFEILERSCHALUNG

Das vielseitige Schalungssystem für Stützpfeiler.

PAX – FORMWORK FOR COLUMNS

The versatile formwork system for columns.

PANAVELOX – SISTEMA CASSERO IN LEGNO

Versatile, semplice, rapido ed economico: il nostro sistema di casseforme PANAVELOX. Il metodo cassaforma PANAVELOX per solai è concepito in maniera da ridurre e semplificare il vostro lavoro in cantiere, consentendovi di lavorare in modo più razionale.

PANAVELOX – HOLZSCHALUNGSSYSTEM

Günstig, vielseitig einsetzbar, einfach und rasch zu montieren: Das Schalungssystem PANAVELOX. Das Deckenschalungssystem PANAVELOX reduziert und vereinfacht Ihren Arbeitsaufwand an der Baustelle und ermöglicht rationalisierte Abläufe.

PANAVELOX – WOODEN FORMWORK SYSTEM

Our PANAVELOX formwork system: versatile, simple, quick and inexpensive. The PANAVELOX formwork method for floor slabs is designed to reduce and simplify your work on site, allowing you to work more efficiently.



Accessori per casseforme | Schalungszubehör | Formwork accessories

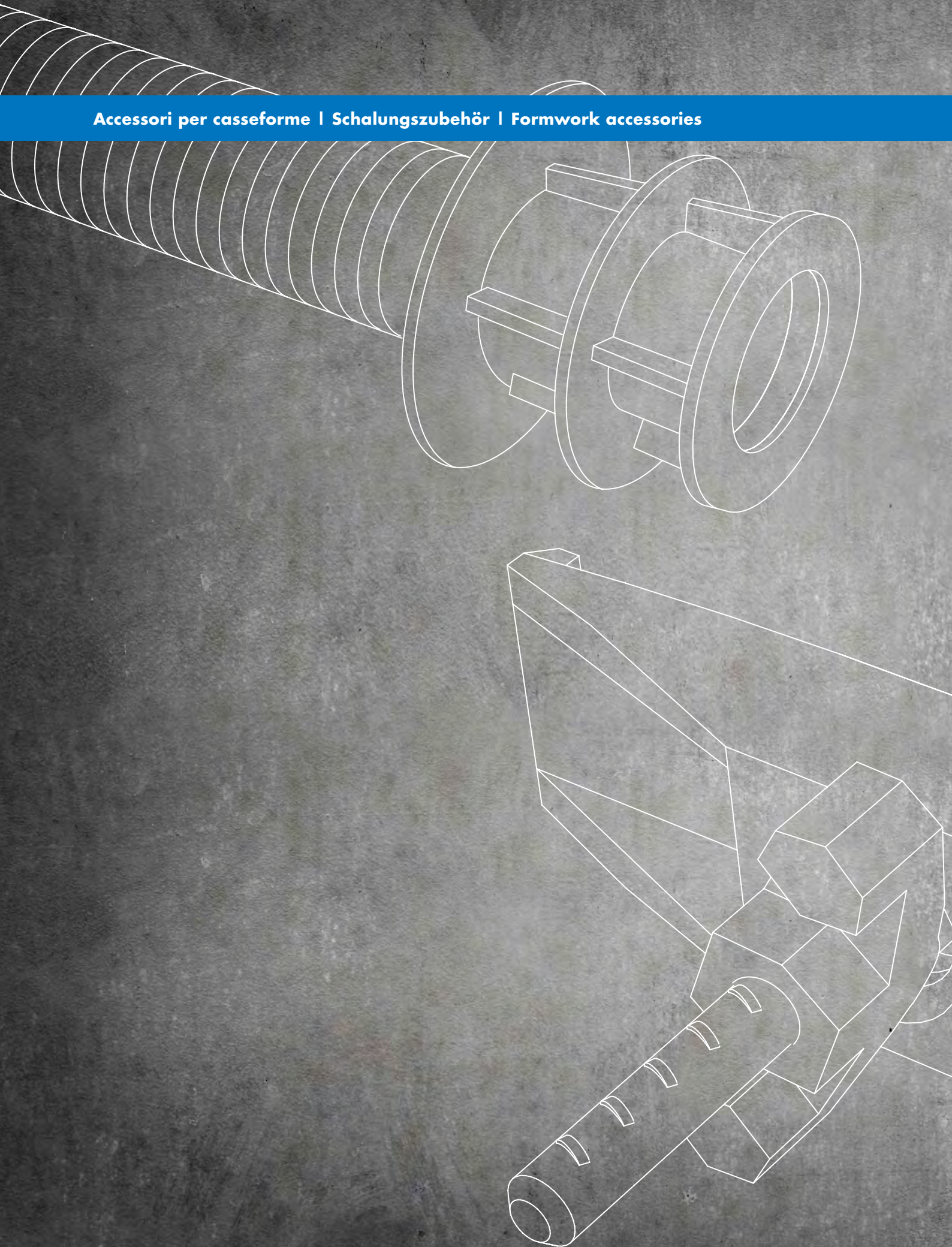



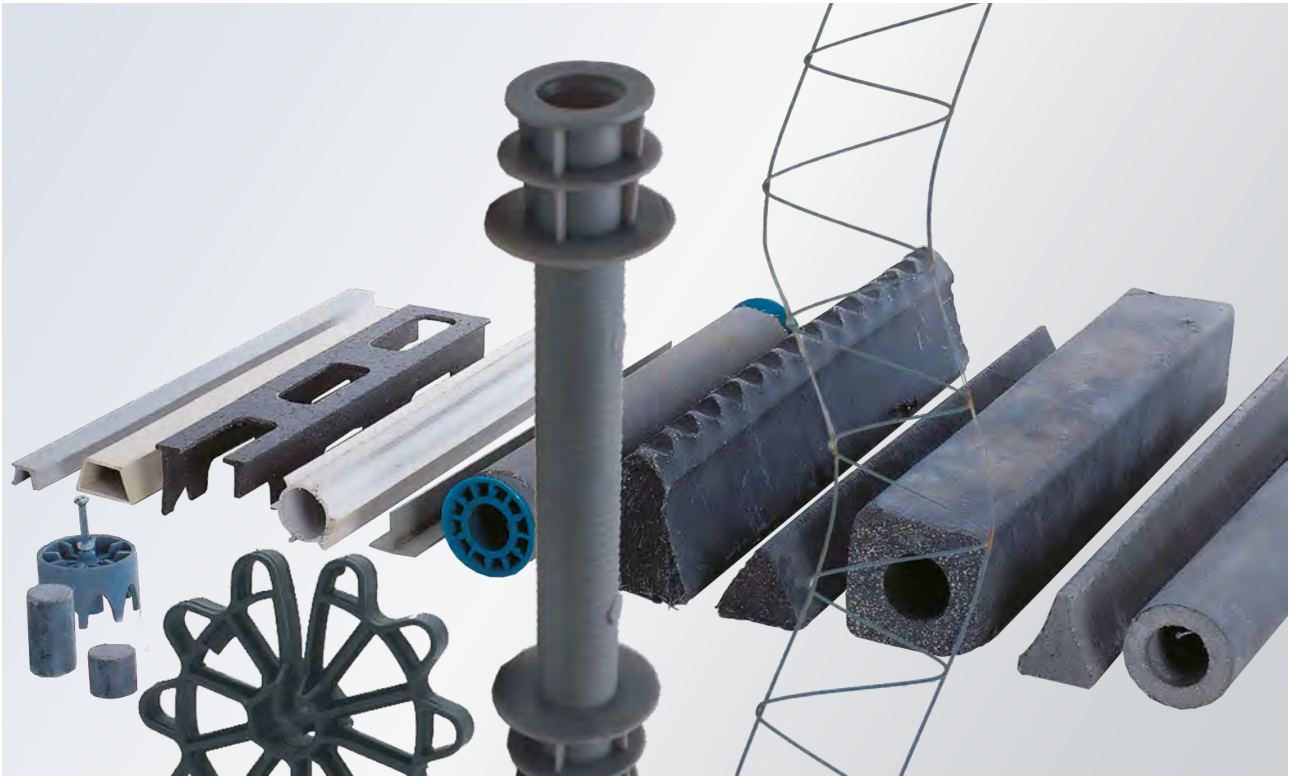

DISTANZIATORI E ACCESSORI

Distanziatori in PVC, fibrocemento e ferro in grado di soddisfare le Vostre esigenze.

ABSTANDHALTER & ZUSATZTEILE

Abstandhalter aus PVC, Faserbeton und Eisen die sich Ihren Bedürfnissen anpassen.

SPACERS AND ACCESSORIES

Spacers made of PVC, fibre-reinforced concrete and iron to meet all your needs.

PANALEX PANAPLAST

Distanziatori in PVC
 Abstandhalter in PVC
 PVC spacers

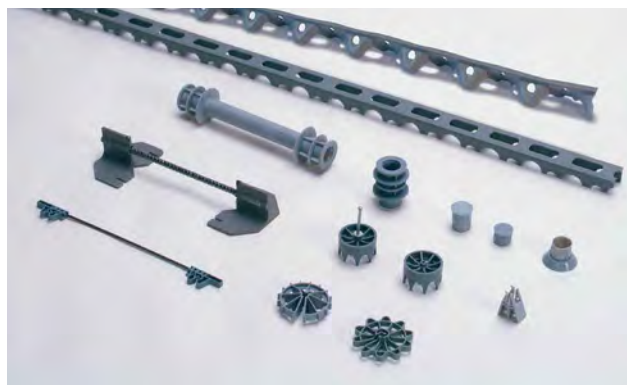

PANALEX PANACEM

Distanziatori in fibrocemento
 Abstandhalter in Faserbeton
 Fibre cement spacers



PANALEX PANARETE

Distanziatori in ferro
 Abstandhalter in Eisen
 Iron spacers

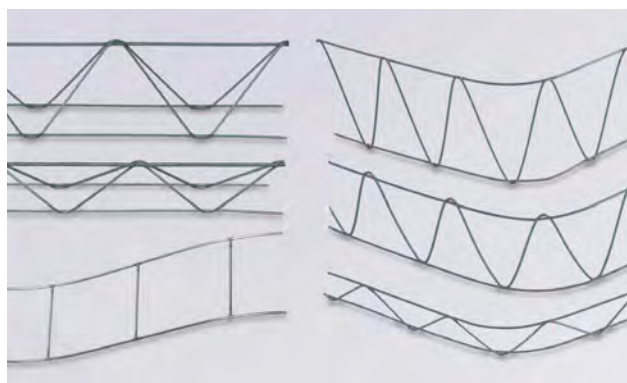

PANALEX Profili

PANALEX Profile
 PANALEX profiles



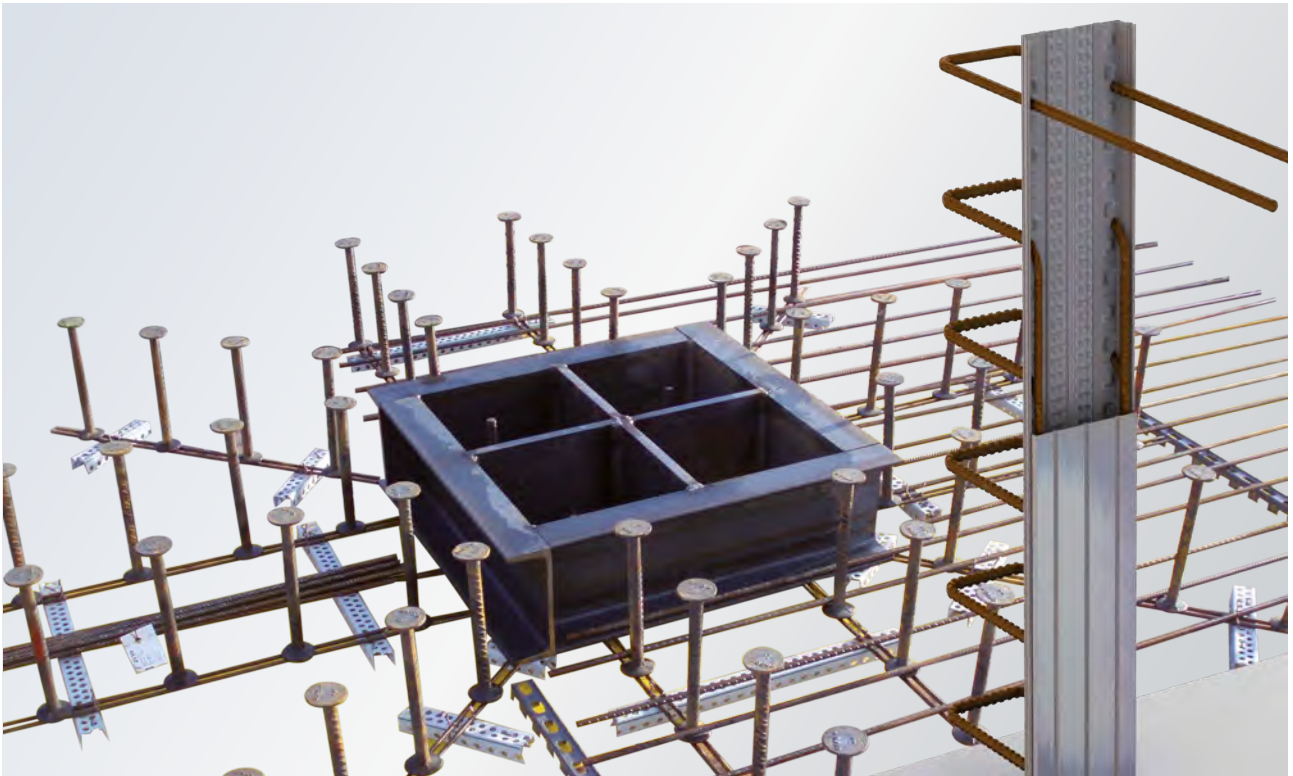

SISTEMI DI ARMATURA

Le armature prefabbricate PANALEX per le giunzioni di pareti, solai, balconi, finestre bocca di lupo o scalinate, parapetti e silos, ecc. sono la base per processi di lavoro sicuri e razionalizzati in tutti i cantieri.

BEWEHRUNGSSYSTEME

Die vorgefertigten PANALEX Bewehrungen für Wand-, Decken-, Balkon-, Kellerschachtanschlüsse bzw. Treppenhäuser, Geländer und Silos usw. sind die Basis für sichere und rationalisierte Arbeitsabläufe auf allen Baustellen.

REINFORCEMENT SYSTEMS

Prefabricated PANALEX reinforcements are the basis for secure and streamlined work processes on all jobsites for wall, ceiling, balcony and basement shaft connections as well as staircases, railings and silos, etc.

LIGHT-BOX Armature di ripresa
LIGHT-BOX Bewehrungsanschlüsse
LIGHT-BOX Reinforcement systems

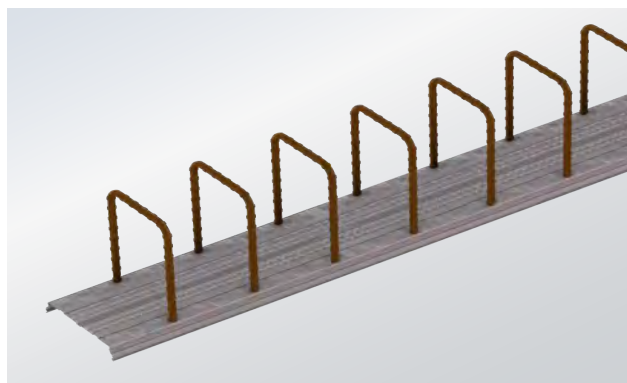

ancoPLUS Rinforzo al taglio
ancoPLUS Durchstanzbewehrung
ancoPLUS Punching prevention system

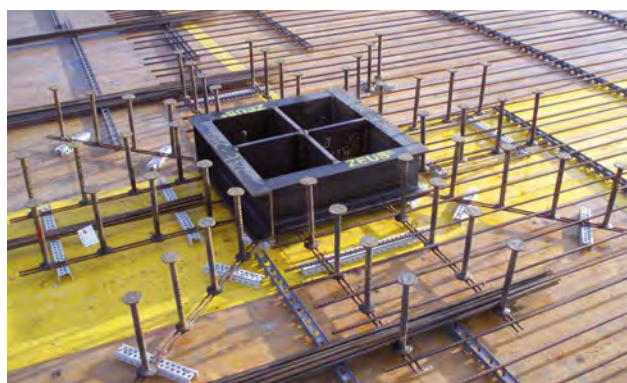

AVI-DE Rinforzo al taglio
AVI-DE Durchstanzbewehrung
AVI-DE Punching shear reinforcement



AVI Thermo-Korb
AVI Thermo-Korb
AVI Thermo-Korb



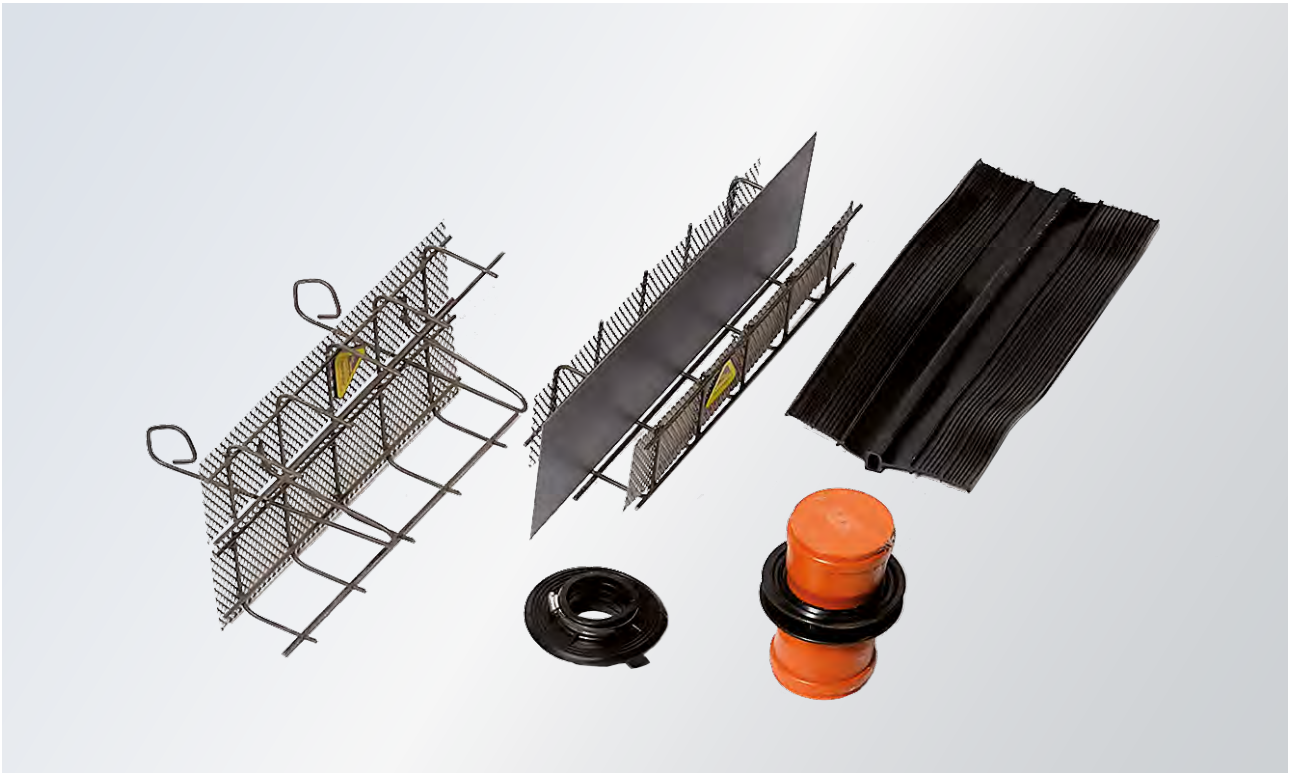

IMPERMEABILIZZAZIONI

Il loro compito è quello di garantire una perfetta tenuta stagna affinché l'acqua non penetri nei punti che devono rimanere asciutti.

BAUWERKSABDICHTUNGEN

Ihre Aufgabe ist, absolut dicht zu halten – damit dort kein Wasser eindringt, wo es trocken bleiben muss.

WATERPROOFING FOR STRUCTURES

The aim is to ensure that no water can penetrate where the area must remain absolutely dry.



Fermagetti
Abschalelemente
Stop end units



TRiGOFORM® Fermagetti
TRiGOFORM® Abschal-
elemente
TRiGOFORM® stop end units



Lamiera a tenuta stagna
Dichtblech
Sealing sheet metal



Waterstop in PVC
Fugenbänder PVC
Waterstop in PVC



Passaggi impermeabili per tubi
Rohrdurchführungen
Feeder sleeves



SISTEMI DI CASSERATURA

A chi desidera tenere sempre sotto controllo tutte le funzioni dei sistemi di cassetta, PANALEX offre accessori perfetti.

SCHALUNGSTECHNIK

Wer alle Funktionen der Schalungstechnik gut im Griff haben will, kann bei PANALEX auf perfektes Zubehör zurückgreifen.

FORMWORK TECHNOLOGY

PANALEX accessories – perfect for providing all the functions of formwork technology.



**PANATUB Casseri in cartone
rotondi**
PANATUB Baurohre rund
PANATUB Tubular formwork

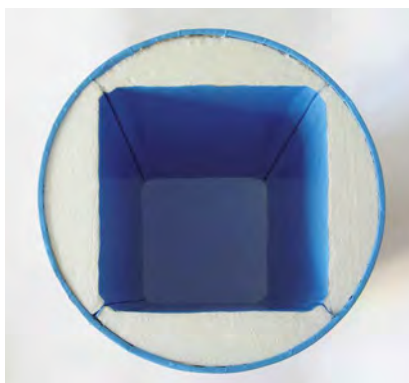

**PANATUB Casseri in cartone
rettangolari / quadrati**
PANATUB Baurohre
rechteckig / quadratisch
PANATUB Rectangular /
square tubular formwork



PANOIL Olio disarmante
PANOIL Entschalungsmittel
PANOIL Release agents



**GLORIA Pompa disarmante
ad alte prestazioni**
GLORIA Hochleistungs-
sprühgerät
GLORIA Pump



PANAPUNT Puntelli
PANAPUNT Stützen
PANAPUNT Prop



UNI Boccola per mensole
UNI Betonhülsen
UNI Concrete bush



RAPID® CLIP®

MORSETTI

Morsetti e tenditori per il bloccaggio delle casseforme nei getti di calcestruzzo.

SCHALUNGSKLEMMEN

Schalungsklemmen und Spanner zum Einspannen und Fixieren von Betonschalungen.

FORMWORK CLAMPS

For locking formworks in concrete castings.



ROLLOTOP®

BARRE E ACCESSORI

L'ancorante si usa come elemento di collegamento per unire pannelli per casseforme.

SCHALUNGSANKER & ZUBEHÖR

Der Schalungsanker dient als Element um Schaltalfel miteinander zu verbinden.

FORMWORK ANCHOR & ACCESSORIES

The formwork anchor serves as an element to connect formwork panels with each other.



GIUNTI PER PONTEGGI

I nostri raccordi e fissaggi per tubi sono perfettamente attrezzati per la massima sicurezza e velocità.

GERÜSTKUPPLUNGEN

Unsere Verbindungen und Fixierungen von Rohren sind bestens gerüstet – für maximale Sicherheit und Schnelligkeit.

SCAFFOLDING COUPLERS

Our pipework connections and fixings are ideally designed for maximum security and speed.

Prodotti in legno | Holzprodukte | Timber products





MULTISTRATO FILMATO

Pannello compensato multistrato con pellicola fenolica e zigrinatura ruvida e liscia.

SPERRHOLZ BEFILMT

Sperrholzplatten phenolharzfilmbeschichtet mit Siebdruck und glatter Oberfläche.

FILMFACED PLYWOOD

Multi-layer phenolic film panels with smooth and anti-slip surfaces.

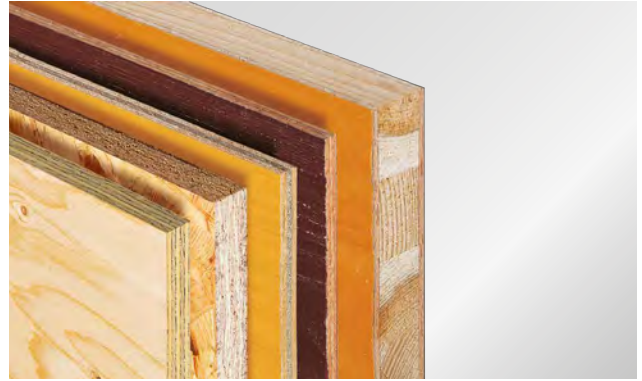

MULTISTRATO GREZZO

Pannelli compensati multistrati senza pellicola fenolica.

SPERRHOLZ ROH

Sperrholzplatten ohne Phenolharzfilm Beschichtung.

RAW PLYWOOD

Multi-layer panels without phenolic film.



TRAVE PER CASSEFORME

La prima trave con protezione integrale rossa in PVC alle estremità.

HOLZSCHALUNGSTRÄGER

Der erste Schalungsträger mit weltweit bewährtem Schutzkappensystem aus PVC.

CONCRETE FORMWORK BEAMS

The first beam with the shock-resistant, bevelled protective cap.

KAUFMANN HT 20 Plus esclusivo sistema di paracolpi angolari

- paracolpi e aletta inseparabili
- paracolpi di materiale plastico di alta qualità
- resistente ai colpi
- protezione efficace contro lo scheggiamento delle estremità delle alette
- nessun rischio di infortuni
- una durata notevolmente più lunga
- Lunghezze standard:
245, 290, 330, 360, 390, 490, 590 cm

KAUFMANN HT 20 Plus einzigartiges Schutzkappensystem

- aus hochwertigem Kunststoff
- schlagfest
- frostunempfindlich
- passgenau eingeschlitzt
- deshalb wirksamer Schutz gegen Absplitterung der Gurtenden
- erheblich längere Lebensdauer
- keine Verringerung der Endauflagefläche
- Standardmaße:
245, 290, 330, 360, 390, 490, 590 cm

KAUFMANN HT 20 Plus globally proven protective cap system

- made of high quality plastic
- shock-resistant
- resistant to frost
- slit accurately
- protection against splintering of the ends
- significantly longer service life
- no reduction of the end supports
- standard legths:
245, 290, 330, 360, 390, 490, 590 cm



PANNELLI PER CASSEFORME A 3 STRATI

Pannelli per casseforme con o senza telaio e con sigillatura dei bordi unica nel suo genere, disponibili in poliuretano.

HOLZSCHALUNGSPLETTEN 3-S BETONSCHALUNGSPLETTEN

Betonschalungsplatten mit und ohne Umleimer sowie mit einzigartiger Kantenversiegelung in Polyurethan erhältlich.

SHUTTERING PANELS 3 LAYER FORMWORK PANEL

We offer concrete formwork panels with and without perimeter frame as well as with unique polyurethane-sealed edges.



KAUFMANN K1

Il pannello leader, senza telaio, a 3-strati, con l'esclusiva sigillatura dei bordi in poliuretano, applicato a caldo.

3-S Betonschalungsplatte ohne Umleimer mit der einzigartigen Kantensiegelung in heiß aufgedrucktem Polyurethan.

Three layer formwork panel without perimeter frame and the unique PU edge sealing.

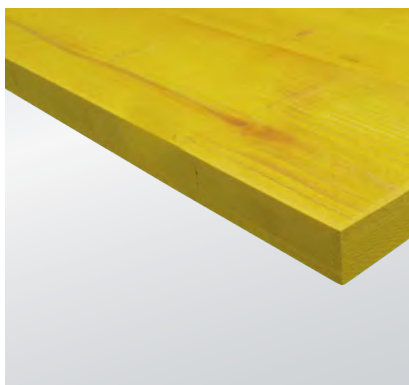

PANALEX S/T Basic

Pannello a 3-strati senza telaio per casseforme

3-S Betonschalungsplatte ohne Umleimer

Three layer formwork panel without perimeter frame



PANALEX C/T Quality

Pannello a 3-strati con telaio per casseforme

3-S Betonschalungsplatte mit Umleimer

Three layer formwork panel with perimeter frame



PANALEX C/T Utility

Pannello a 3-strati con telaio per casseforme

3-S Betonschalungsplatte mit Umleimer

Three layer formwork panel with perimeter frame

Servizio | Service | Service

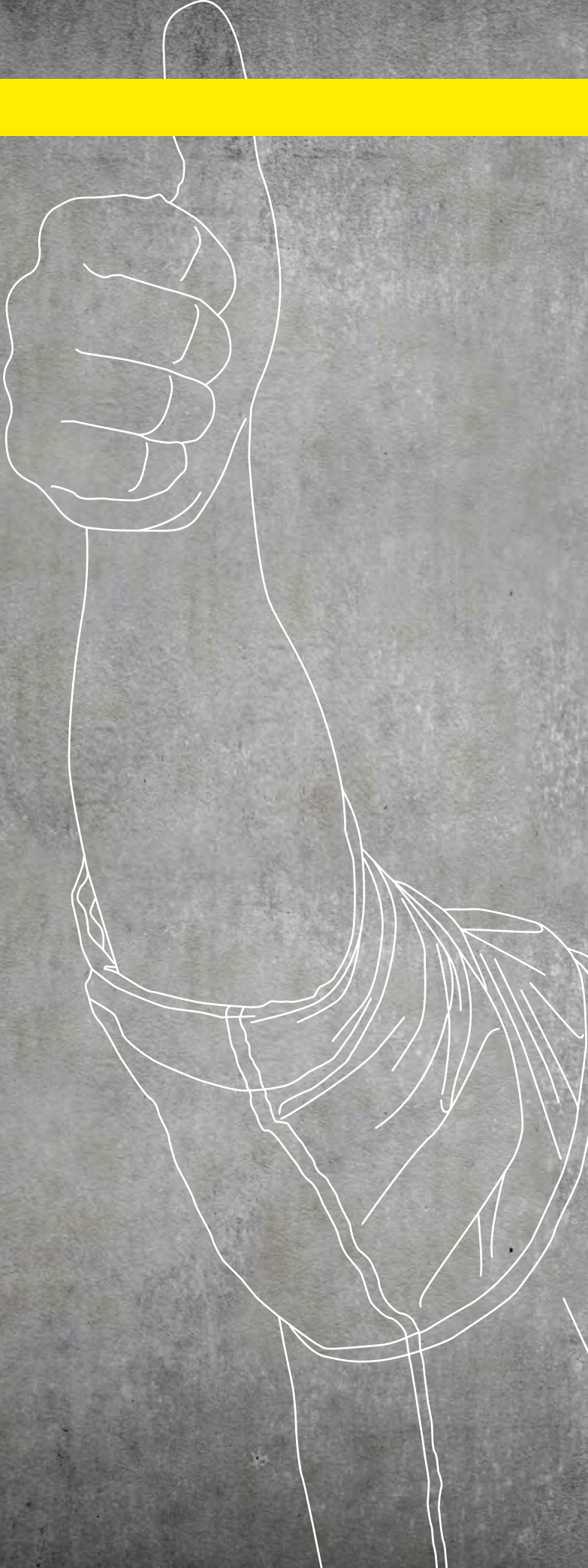



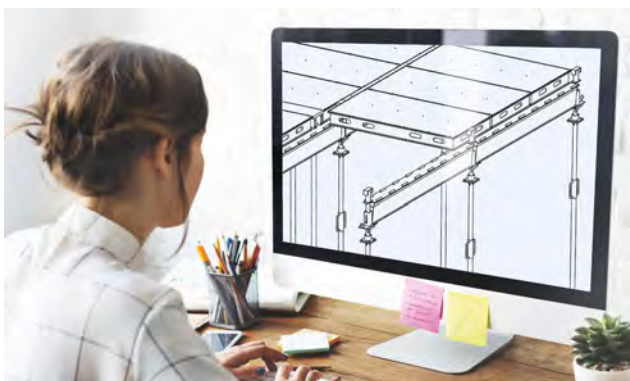

NOVITÀ

NOLEGGIO E PROGETTAZIONE DI CASSEFORME

Noleggiamo casseforme per pilastri, pareti e solai, ponteggi di sostegno e puntelli con accessori. Realizziamo su richiesta il disegno delle Vostre casseforme a fronte di un sovrapprezzo.

NEUHEIT

SCHALUNGSMIETE & PLANUNG

Wir vermieten Pfeilerschalungen, Wand- und Deckenschalungen, Stützgerüste und Stützen mit Zubehör. Falls gewünscht erstellen wir Ihnen gegen Aufpreis den Schalplan.

NEWS

FORMWORK RENTAL & PLANNING

We rent out pillar formwork, wall and ceiling formwork, support scaffolding and supports with accessories. We can also develop your formwork plan (extra charge applicable).

LOGISTICA

Affidatevi a noi per consegne puntuali con i nostri veicoli in tutto l'Alto Adige, a Trento e a Verona, e tramite i nostri autotrasportatori di fiducia in tutta Europa.

LOGISTIK

Sie können sich darauf verlassen, dass wir pünktlich liefern: in ganz Südtirol, Trient und Verona mit eigenem Fahrzeug, europaweit mit verlässlichen Frächtern.

LOGISTICS

You can rest assured that we will deliver on time, with our own vehicles in South Tyrol, Trento and Verona, or with reliable hauliers throughout Europe.

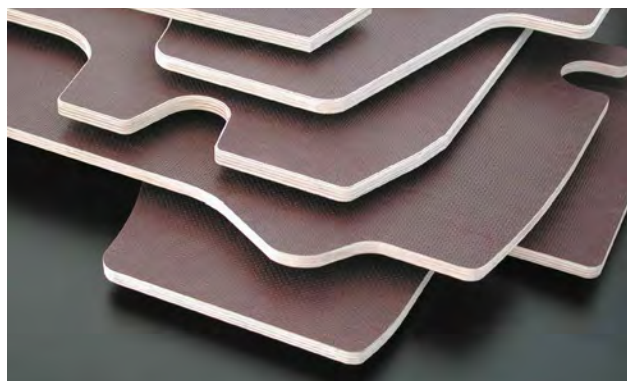

RIPRISTINO CASSEFORME

Ripristino casseforme in 3 interventi:

1. Pulizia cassaforma / rigenerazione manto.
2. Servizio di sostituzione manto con accessori.
3. Fornitura del manto con accessori.

SCHALUNGSRENOVIERUNG

Schalungsrenovierung in 3 Leistungsstufen:

1. Schalungsreinigung / Sanierung Schalhaut.
2. Austausch Schalhaut inkl. Zubehör.
3. Lieferung der Schalhaut inkl. Zubehör.

FORMWORK RENEWAL

3-step action plan for formwork renewal:

1. Formwork cleaning / formwork renovation.
2. Replacement of form-facing with accessories.
3. Delivery of form-facing with accessories.

LAVORAZIONE CNC

Nel nostro moderno centro di lavorazione eseguiamo tagli su misura e lavorazioni su richiesta con l'impianto a CNC secondo i Vostri disegni.

PLATTENZUSCHNITT

Fixmaßzuschnitte und CNC-Bearbeitungen nach Ihren Zeichnungen, führen wir in unserem modernen Bearbeitungszentrum gerne für Sie aus.

MADE-TO-MEASURE PANELS

We will be pleased to realise fixed-size cutting jobs and CNC processing according to your drawings in our modern processing centre.

Sistema Casseforme Systemschalung Concrete formwork system

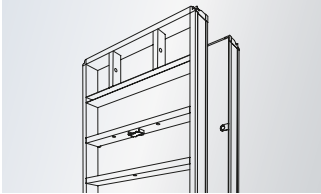

Cassero a telaio
Rahmenschalung
Framed formwork

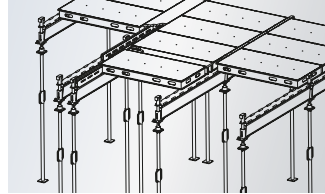

PANADECK Cassaforma
per solaio
PANADECK Deckenschalung
PANADECK slab formwork



Cassaforma per pilastri
Stützenschalung
Formwork for pillars



Sistema cassero in legno
Holzschalungssystem
Wooden formwork system

Accessori per casseforme Schalungszubehör Formwork accessories

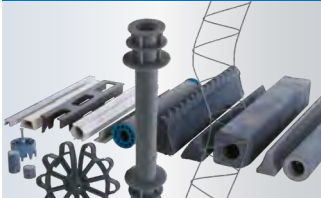

Distanziatori & Accessori
Abstandhalter & Zusatzteile
Spacers & fittings

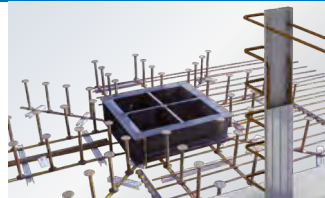

Sistemi d'armatura
Bewehrungssysteme
Reinforcement systems



Impermeabilizzazioni
Bauwerksabdichtungen
Structural waterproofing



Sistemi di cassetta
Schalungstechnik
Formwork accessories



Morsetti
Schalungsklemmen
Formwork clamps



Barre e accessori
Schalungsanker & Zubehör
Formwork anchor & accessories



Giunti per ponteggi
Gerüstkupplungen
Scaffolding couplers

Prodotti in legno Holzprodukte Timber products



Multistrato filmato
Sperrholz befilmt
Filmfaced plywood

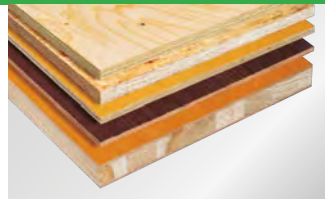

Multistrato grezzo
Sperrholz roh
Raw plywood

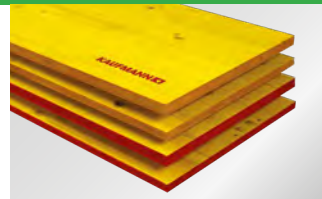

Pannelli per casseforme
Holzschalungsplatten
Shuttering panels



Trave per casseforme
Holzschalungsträger
Concrete formwork beams

Servizio Service Service



Noleggio casseforme &
progettazione
Schalungsmiete & Planung
Formwork rental & planning



Logistica
Logistik
Logistics



Ripristino casseforme
Schalungsrenovierung
Formwork renewal



Lavorazione pannelli
Plattenzuschnitt
Machined panels

Siamo vicinissimi a voi

Abbiamo un rapporto stretto e speciale con i nostri clienti. Questo perché li conosciamo e sappiamo non solo quanto sia duro il loro lavoro, ma anche quanto è spietata la loro concorrenza. Il nostro punto di partenza è la realtà: ci sprona a trasformare i problemi in soluzioni per offrire la massima sicurezza possibile con un elevatissimo livello di efficienza. Va da sé che anche le nostre sedi sono state scelte in modo da soddisfare ampiamente le esigenze dei nostri clienti.

Wir sind Ihnen ganz nah

Zu unseren Kunden haben wir ein besonderes Nahverhältnis. Das ist liegt daran, dass wir unsere Kunden, ihren harten Job und ihren ebenso harten Wettbewerb kennen. Für uns ist diese Realität die Voraussetzung, um Probleme in Lösungen umzusetzen, um grösstmögliche Sicherheit bei maximaler Effizienz anzubieten. Naheliegend, dass auch unsere Standorte so ausgewählt wurden, dass sie unseren Kunden ein grosses Stück entgegenkommen.

We are nearby

We have a special relationship with our customers, because we know them, the hard nature of their work and the equally tough competition out there. For us, reality is the requirement in implementing solutions to problems and offering maximum safety with maximum efficiency. So it goes without saying that our locations have been chosen with proximity to our customers in mind.



Sede e smistamento
Firmensitz & Lager
HQ and warehouse
PANALEX GmbH
Industriezone 16
I-39030 Olang/BZ
T +39 0474 49 50 00
F +39 0474 49 50 50
E info@panalex.it

Centro di smistamento
Auslieferungslager
Distribution centre
PANALEX Srl
Zona Industriale
Via Tasso 20
I-37010 Albarè di
Costermano/VR

Produzione
Produktion
Production
PANALEX S.R.O.
Milady Horákové 2724
CZ-27201 Kladno
E info@panalex.cz

Hauptsitz | Sede centrale

PANALEX GmbH
Industriezone 16
I-39030 Olang/BZ/Italy
T +39 0474 49 50 00
F +39 0474 49 50 50
E info@panalex.it
www.panalex.it

Logistik | Logistica**Produktion | Produzione**

I-39030 Olang/BZ
I-37010 Albaré di
Costermano/VR
CZ-27201 Kladno

AspettateVi da parte nostra una collaborazione costruttiva e soluzioni produttive.
Erwarten Sie von uns konstruktive Zusammenarbeit und produktive Lösungen.
You can expect from us constructive cooperation and productive solutions.

■ **Sistema Casseforme**
Systemschalung
Concrete formwork system

■ **Accessori per casseforme**
Schalungszubehör
Formwork accessories

■ **Prodotti in legno**
Holzprodukte
Timber products

■ **Servizio**
Service
Service