

PANAWALL Sistema Casseforme
PANAWALL Systemschalung
PANAWALL Concrete formwork system



Cemento in forma
Alles in Schalung
All for formwork



Cemento in forma

Alles in Schalung

All for formwork



Cemento in forma

La pluriennale esperienza maturata da PANALEX Srl nel settore dei pannelli e dei rivestimenti speciali per casseforme, impalcature e trasporti affonda le sue radici in una passione nata oltre 30 anni fa e permette soluzioni uniche per clienti esigenti nel settore edile e dei trasporti.

Alles in Schalung

Die langjährige Erfahrung, die PANALEX GmbH im Bereich Platten und Spezialbeschichtungen für Schalungsbau, Gerüstbau und Transportwesen sammeln konnte, hat ihren Ursprung in einer vor mehr als 30 Jahren entstandenen Leidenschaft: Einzigartige Lösungen für anspruchsvolle Kunden im Bau- und Transportsektor.

All for formwork

The many years of experience that PANALEX GmbH possesses in the areas of panels and special coatings for formwork construction, scaffolding and transportation all originate in a passion that was developed over thirty years ago: unique solutions for demanding customers in the construction and transport sector.

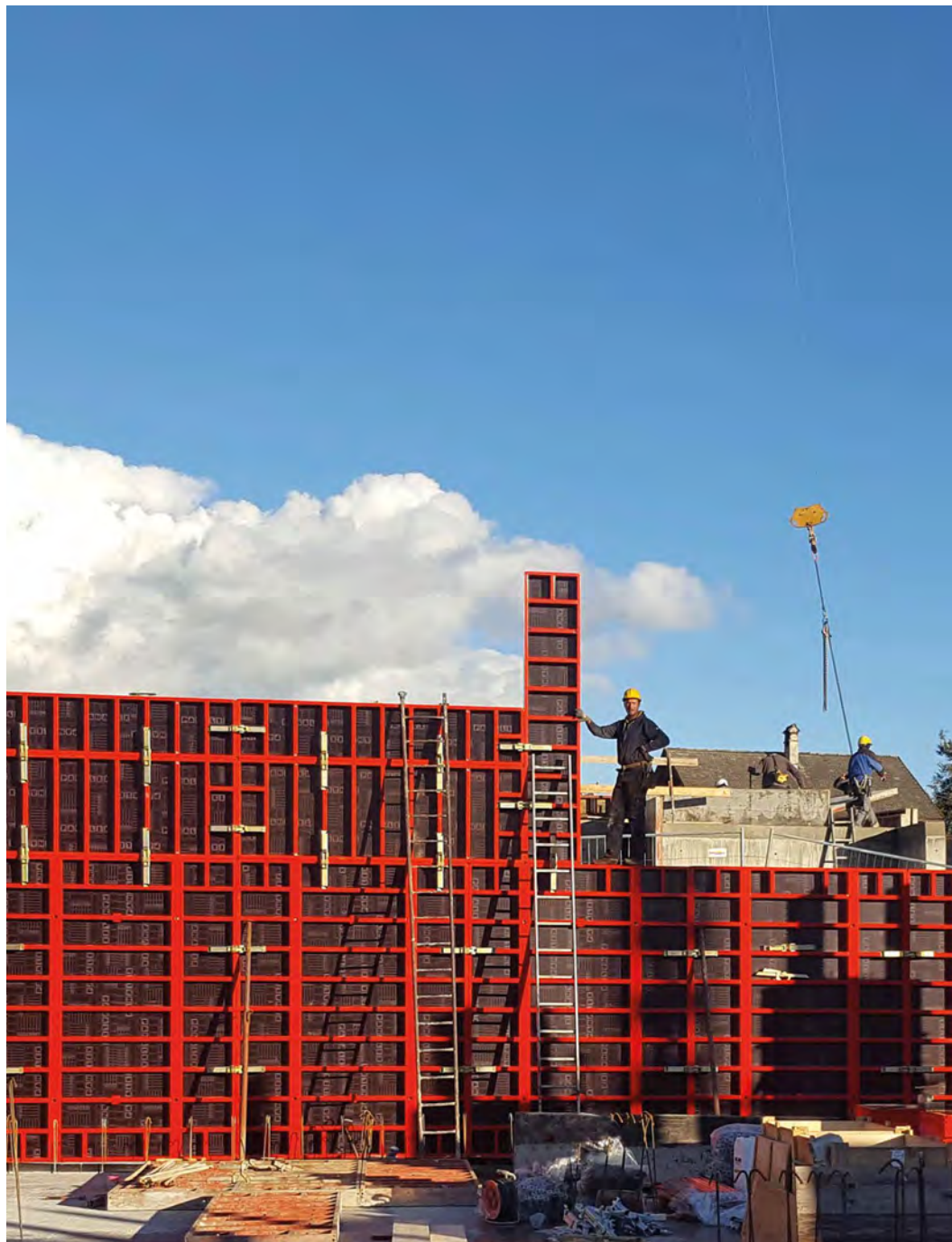



Pacchetti a 360° per i nostri clienti

PANALEX Srl si è affermata come fornitore a 360° di servizi innovativi e di tutti i prodotti per casseforme. Dalla produzione al noleggio sino alla pianificazione operativa di sistemi di casseforme, la gamma comprende anche pannelli e travi per casseforme in legno, soluzioni speciali per calcestruzzo a vista, distanziatori, accessori per casseforme, sistemi di armatura e di impermeabilizzazione delle opere (vasche bianche).

Rundum-Paket für unsere Kunden

PANALEX GmbH hat sich nunmehr als Komplettanbieter von innovativen Dienstleistungen und allen Produkten rund um das Schalen etabliert. Neben der Produktion, Vermietung sowie der Einsatzplanung von Systemschalung umfasst die Produktpalette auch Betonschalungsplatten und Träger aus Holz, Sonderlösungen für Sichtbeton, Abstandhalter, Schalungszubehör, Bewehrungssysteme und Bauwerksabdichtung (weiße Wanne).

An all-round package for our customers

PANALEX GmbH has established itself as a complete provider of innovative products and services for formwork: as well as the production, hiring and operational planning of formwork systems, our product range also covers wooden panels and supports for concrete formwork, special solutions for exposed concrete, spacers, casting accessories, reinforcement systems and building waterproofing (white tank).

Indice

Inhaltsverzeichnis

Index

	Pagina		Seite		Page
Casseforme a telaio	6	Rahmenschalungen	6	Formwork system	6
PANAWALL Pannelli	7	PANAWALL Elemente	7	PANAWALL Panels	7
Angoli-Compensi	9	Ecken-Ausgleiche	9	Corner-Compensations	9
Accessori di collegamento	10	Verbindungszubehör	10	Connecting parts	10
Ancoraggio unilaterale	11	Einseitige Ankerbedienung	11	One-sided tie operation	11
Sicurezza e trasporto	13	Sicherheit und Transport	13	Safety and transport	13
Rassegna articoli	14	Artikelliste	14	Item list	14
Famiglia prodotti	29	Produktübersicht	29	Product overview	29

Le immagini del presente catalogo mostrano situazioni di cantiere in evoluzione e sono pertanto oggetto di verifica per la sicurezza tecnica.
Die Fotografien in dieser Broschüre zeigen Baustellensituationen. Es kann also möglich sein, dass die Richtlinien zur Arbeitssicherheit nicht berücksichtigt wurden.
The photos of the current brochure are showing various situations on the construction site in development and are subject for examination of technical security.

Avvertenze importanti:

L'impiego delle attrezzature provvisorie è soggetto alle prescrizioni dettate dalle leggi e dalle norme vigenti nei vari Stati, atte a garantire il più elevato livello di sicurezza per l'utilizzo di tali attrezzature. Devono essere osservate le istruzioni specifiche per l'impiego inteso e le limitazioni d'uso. Qualora l'utilizzazione delle attrezzature non rientri per dimensioni e/o sovraccarichi nel campo d'impiego, definito dagli schemi funzionali, ovvero si fa ricorso a configurazioni d'attrezzatura differenti dagli schemi funzionali „tipo“, deve essere redatta una specifica relazione di calcolo. Le fotografie riportate in questo opuscolo sono immagini istantanee, che documentano situazioni reali di cantiere. Per questo motivo, soprattutto i particolari relativi ai sistemi d'ancoraggio ed alla sicurezza nell'impiego delle attrezzature non sono sempre da considerarsi conformi alle norme per la prevenzione degli infortuni sul lavoro nelle costruzioni. Pertanto le immagini non devono essere intese come esempi d'impiego. La PANALEX, perseguendo una politica di continuo miglioramento tecnologico si riserva il diritto di apportare, in qualsiasi momento, senza preavviso, modifiche tecniche per osservare le normative nei vari Stati.

Wichtige Hinweise:

Zur Gewährleistung maximaler Sicherheit wird der Einsatz temporärer Konstruktionen von den geltenden einschlägigen Bestimmungen und Gesetzen des jeweiligen Einsatzlandes geregelt. Es sind spezifische Anweisungen für die vorgesehene Verwendung sowie Nutzungseinschränkungen zu beachten. Wann immer der Einsatz der temporären Konstruktionen aufgrund ihrer Abmessungen und/oder ihrer Belastung nicht dem von den Funktionsschemata vorgegebenen Einsatzbereich entspricht oder von den Typen-Funktionsschemata abweichende Konfigurationen aufweist, muss ein eigener Bemessungsnachweis erstellt werden. Bei den hier enthaltenen Abbildungen handelt es sich um Fotografien realer Baustellensituationen. Aus diesem Grund ist nicht immer davon auszugehen, dass Detailansichten von Verankerungs- und Sicherheitssystemen beim Einsatz der temporären Konstruktionen den geltenden Bestimmungen zur Unfallprävention am Bau entsprechen. Die Abbildungen verstehen sich lediglich als Einsatzbeispiele. Im Sinne der kontinuierlichen technologischen Verbesserungen behält sich PANALEX vor, jederzeit und ohne Vorankündigung technische Änderungen zur Anpassung an die Bestimmungen der verschiedenen Einsatzländer vorzunehmen.

Important information:

The use of temporary equipment is subject to the various national laws and regulations in force that can ensure the highest level of safety for the use of such temporary equipment. The specific instructions for the intended use and the limitations on use must be observed. If temporary equipment cannot be used owing to its dimensions and/or possible overload in the area of use as defined by the functional diagrams, or if equipment configurations other than the „typical“ functional diagrams are used, specific calculation reports must be drawn up. The photographs shown in this booklet are snapshots that document actual construction site situations. For this reason, the details relating to the anchoring systems and safety in the use of temporary equipment are in particular not to be considered as at all times compliant with the rules for the prevention of accidents at work on construction sites. The photographic images are therefore not intended as examples of use. As part of its policy of continuous technological improvement, PANALEX reserves the right to make technical changes at any time, without notice, to comply with various national regulations.

I contenuti sono stilati con la massima cura. Possono tuttavia riscontrarsi errori in merito all'esattezza e alla completezza dei quali non si assume alcuna responsabilità.

Trotz sorgfältiger Prüfung kann für die Richtigkeit der Inhalte keine Haftung übernommen werden.

Contents are described with the greatest care. However we do not assume any responsibility for the accuracy and completeness.

PANAWALL Casseforme a telaio di ottima qualità

PANAWALL Rahmenschalungen in Top-Qualität

PANAWALL Top-quality formwork system

NOVITÀ

Con PANAWALL e PANAWALL PLUS di PANALEX, disporrete del sistema ideale per far fronte a ogni sfida ed esigenza costruttiva. Un solido telaio in acciaio con speciale profilo perimetrale consente una semplice applicazione delle morse di serraggio, con un'efficiente funzione di allineamento e collegamento.

NEUHEIT

Mit PANAWALL und PANAWALL PLUS von PANALEX erwerben Sie das ideale Schalensystem für Ihre An- und Herausforderungen am Bau. Ein starker Stahlrahmen mit umlaufendem Spezialprofil ermöglicht das einfache Anbringen des effizient ausrichtenden und verbindenden Richtschlosses.

NEWS

PANAWALL and PANAWALL PLUS from PANALEX offer you the ideal formwork system for every type of construction challenge. A strong steel frame with a surrounding special profile permits easy attachment of the connecting clamp for effective alignment and connection.



PANAWALL Pannelli

PANAWALL Elemente

PANAWALL Panels

L'altezza degli elementi di cassaforma, dotati di due boccole di serraggio per l'ancoraggio, è pari a 300 cm (PW con 3 boccole di serraggio). L'offerta di elementi di svariata ampiezza consente un'armatura semplice e rapida delle pareti in calcestruzzo di ogni geometria. Le casseforme possono essere utilizzate tanto in verticale quanto in orizzontale.

Die Höhe der Schalungselemente, welche mit 2 Spannhülsen (PW-Serie mit 3 Spannhülsen) zum Durchankern versehen sind, beträgt 300 cm. Das Angebot an verschiedenen Elementbreiten ermöglicht ein schnelles und einfaches Einschalen von Betonwänden jeder Geometrie. Die Schalungen können sowohl vertikal als auch horizontal eingesetzt werden.

The formwork elements are 300 cm in height and have two clamping sleeves for anchoring purposes (PW with 3 clamping sleeves). The various element widths make it a quick and simple task to apply formwork to concrete walls of any geometry. The formwork can be arranged both vertically and horizontally.

PWP 300

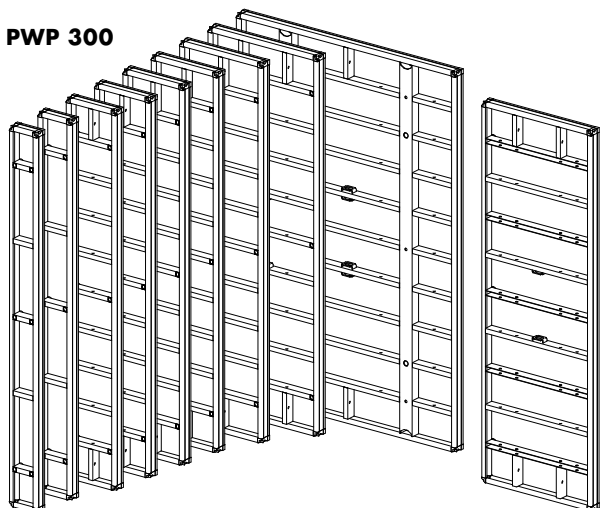

Altezza 300 cm
Höhe 300 cm
Height 300 cm

PW 300

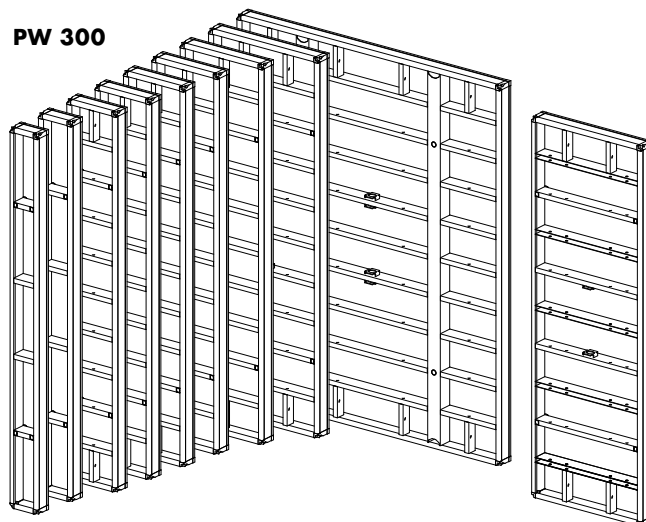

Altezza 300 cm
Höhe 300 cm
Height 300 cm

PWP 150

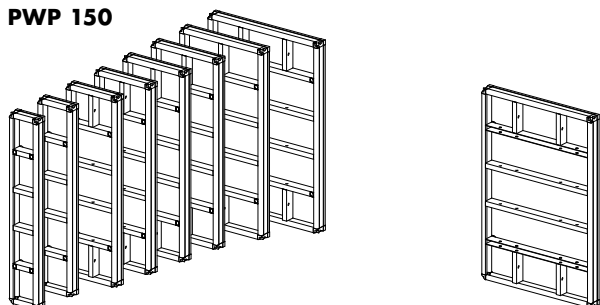

Altezza 150 cm
Höhe 150 cm
Height 150 cm

PW 150

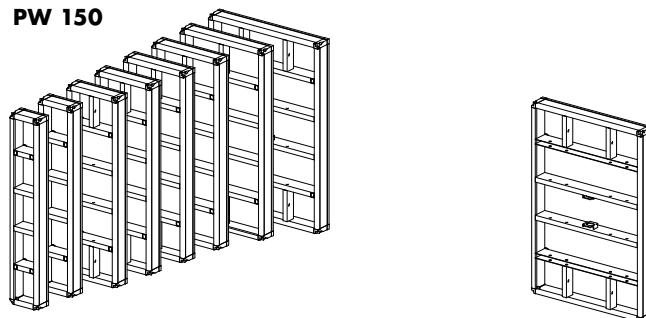

Altezza 150 cm
Höhe 150 cm
Height 150 cm



Telaio di qualità

Il cassero a telaio PANAWALL è un sistema modulare di casseforme per pareti (necessitante di gru) adatto alla costruzione di edifici abitativi e industriali, opere ingegneristiche e infrastrutture.

Il profilo telaio è in acciaio pregiato a grana fine:

per PW – spessore profilo 100 mm
per PWP – spessore profilo 140 mm.

Qualitätsrahmung

Die PANAWALL Rahmenschalung ist ein kranabhängiges, modulares Rahmenschalungssystem für den Einsatz im Wohnungs-, Industrie- und Infrastrukturbau.

Das Rahmenprofil besteht aus hochwertigem Feinkornstahl:

bei PW – 100 mm Profilhöhe
bei PWP – 140 mm Profilhöhe.

Frame quality

PANAWALL formwork system is a craneoperated wall formwork system for use in residential, engineering and infrastructure construction.

The formwork profile is made of high quality fine-grain steel:

with profile height PW – 100 mm
with profile height PWP – 140 mm.



Manto di qualità

Manto di qualità con spessore di 18 mm e struttura speciale in legno di betulla impiallacciato e incollato 13 volte. Superfici dei pannelli multistrato con rivestimento standard in pellicola fenolica marrone scuro di 220g/m² per lato.

Sovrapprezzo per i seguenti optional:

- rivestimento in plastica grigia di 1,3 mm su entrambi i lati.
- o pannello completamente in plastica anziché in legno di betulla multistrato.

Qualitätsschalhaut

Qualitätsschalhaut 18 mm mit Sonderaufbau aus 13-fach verleimten Birkenfurnieren. Oberflächen dieser Sperrholzplatten als Standard mit Phenolharzfilm dunkelbraun 220g/m² je Seite befilmt.

Optionals gegen Aufpreis:

- Beidseitige Kunststoffbeschichtung grau 1,3 mm.
- Oder anstelle der Sperrholzplatte aus Birke, die Platte komplett aus Kunststoff.

Quality formwork

Quality 18 mm multilayer panel, special construction of 13 layers of glued birch veneers. The surfaces of these plywood panels are coated as standard with dark brown phenolic resin film 220g/m² on each side.

Optional extras (surcharge payable):

- 1.3 mm grey plastic coating on both sides.
- Or panel completely of plastic instead of birch plywood.

Angoli-Compensi

Ecken-Ausgleiche

Corner-Compensations

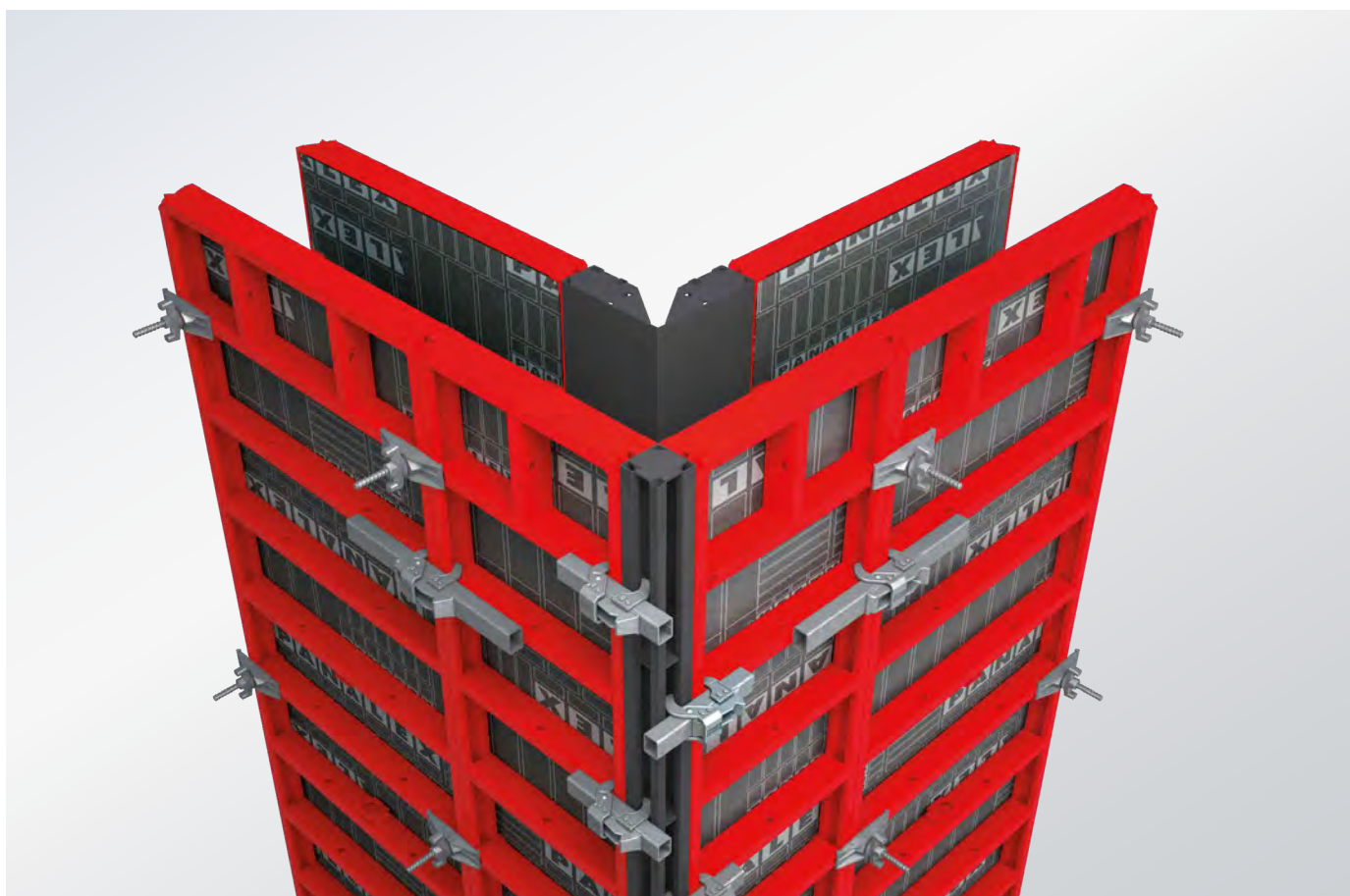

Elementi ad angolo retto, così come elementi angolari a cerniera in acciaio consentono l'armatura di angoli muro e pozzetti, così come di raccordi muro in svariate geometrie.

Con l'aiuto di lamiera, profili e aste di compensazione e profili di disarmo, vengono colmate senza soluzione di continuità le dimensioni residue dell'armatura di pozzetti, muri di collegamento e intermedi e le commettiture di 0–30 cm.

La verniciatura a polvere di questi elementi impedisce una rapida formazione della ruggine, contrastando gli agenti esterni.

Rechtwinklige als auch bewegliche Eckelemente in Stahl ermöglichen das Einschalen von Mauerecken, Schächten sowie Maueranschlüssen in verschiedenen Geometrien.

Mit Hilfe von Ausgleichsblechen, Ausgleichsstäben, Ausgleichsprofilen und Ausschaltprofilen werden Restmaße beim Einschalen von Schächten, Anschlussmauern bzw. Zwischenmauern und Stoßfugen von 0–30 cm stufenlos überbrückt.

Die Pulverbeschichtung dieser Elemente verhindert ein schnelles Rosten und wirkt widerstandsfähig gegen äußere Einwirkungen.

Fixed angle and hinged corner elements in steel allow formwork to be applied to wall corners, shafts and wall connections of different geometries.

Using filler plates, filler profiles and variable or striking profiles, residual dimensions of 0–30 cm can be seamlessly bridged when applying formwork in shafts, connection and/or party walls and impact joints.

The powder coating of these elements prevents rapid rusting and resists external effects.



Morse di serraggio PX

Le morse di serraggio PX collegano due pannelli, orientandoli in linea retta. Grazie agli efficienti cunei di bloccaggio, il collegamento di due elementi diventa semplice, sicuro e pratico in ogni punto del telaio, in particolare nelle traverse. In caso di utilizzo di elementi di compensazione, il collegamento viene effettuato mediante morse di compenso.

Richtschloss PX

Das Richtschloss PX verbindet zwei Wandelemente und richtet diese geradlinig aus. Durch den effizienten Keilverschluss ist das Verbinden zweier Elemente an jeder Stelle des Elementrahmens, vorzugsweise an den Rahmensprossen, einfach, handlich und sicher auszuführen. Bei Verwendung von Ausgleichselementen wird die Verbindung mittels Schraubverschluss hergestellt.

Connecting clamp PX

The connecting clamp PX connects two panels and aligns them in a straight line. The efficient wedging action is simple, practical and safe to connect the two elements at any place on the element framework (preferably on the framework rungs). When using compensating elements the connection is realised by means of connecting clamp PX.

Ancoraggio unilaterale
Einseitige Ankerbedienung
One-sided tie operation

Casseri con gestione unilaterale degli ancoranti

I grandi elementi PW e PWP sono dotati di bussola di sostituzione di serie. Se la gestione degli ancoranti avviene su un unico lato, la bussola deve essere sostituita con il dado a innesto nella faccia di cassetta.

Schalen mit einseitiger Ankerbedienung

PW und PWP Großelemente sind serienmäßig mit der Wechselhülse ausgerüstet. Wenn die Ankerbedienung einseitig erfolgen soll, ist bei der Stellschalung die Wechselhülse gegen die Einsteckmutter zu tauschen.

Formwork with single-sided anchor operation

PW and PWP large elements are fitted as standard with exchangeable sleeves. If the anchor operation is on one side only, the exchangeable sleeve must be replaced with the insert nut on the holding formwork.

Ancoraggio unilaterale

Einseitige Ankerbedienung

One-sided tie operation

Cassero di chiusura

Aprire il blocco di chiusura e rimuovere la bussola di sostituzione a cono. Inserire la barra ancorante con il distanziatore montato e avvitare il dado a innesto sul lato opposto sino in fondo (pari a circa min. 5 giri completi). Inserire la bussola di sostituzione a cono e serrare il dispositivo di blocco. Fissare la piastra combinata.

Avvertenza: il cassero di chiusura dovrebbe essere posizionato con spessore della parete + 1 cm.

Schließschalung

Die Verriegelung öffnen und die Konus-Wechselhülse entnehmen. Ankerstab mit aufgestecktem Abstandhalter einführen und in die gegenüberliegende Einsteckmutter bis zum Anschlag eindrehen (entspricht mind. 5 vollständigen Umdrehungen). Konus-Wechselhülse einführen, danach die Verriegelung schließen. Gelenkplatte festziehen.

Hinweis: die Schließschalung sollte mit Wandstärke + 1 cm gestellt werden.

Closing formwork

Open the locking mechanism and remove the Konus exchangeable sleeve. Insert the tie rod with spacer attached and screw into the insert nut opposite until it reaches the stop point (equivalent to at least 5 full turns). Insert the Konus exchangeable sleeve then close the locking mechanism. Tighten combined board.

N.B.: the closing formwork should be positioned at wall thickness + 1 cm.



Aprire il dispositivo di bloccaggio, rimuovere la bussola di sostituzione a cono
Verriegelung öffnen, Konus-Wechselhülse entnehmen
Open the locking mechanism and remove the Konus exchangeable sleeve



Avvitare la barra ancorante con il distanziatore
Ankerstab mit Abstandhalter einschrauben
Screw in the tie rod with spacer



Inserire e serrare la bussola di sostituzione a cono
Konus-Wechselhülse einführen und verriegeln
Insert Konus exchangeable sleeve and lock



Fissare la piastra combinata – fatto!
Gelenkplatte festziehen – fertig!
Tighten combined board – done!

Faccia casseraura Stellschalung Holding formwork



Aprire il dispositivo di blocco
Verriegelung öffnen
Open locking mechanism



Rimuovere la bussola di sostituzione a cono
Konus-Wechselhülse entnehmen
Remove Konus exchangeable sleeve



Inserire il dado a innesto, serrare il dispositivo di blocco
Einsteckmutter einführen, Verriegelung schließen
Introduce insert nut, close locking mechanism

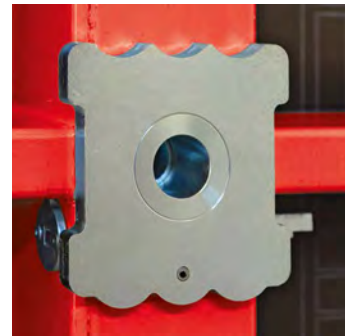

Dado a innesto inserito
Einsteckmutter eingebaut
Insert nut in position

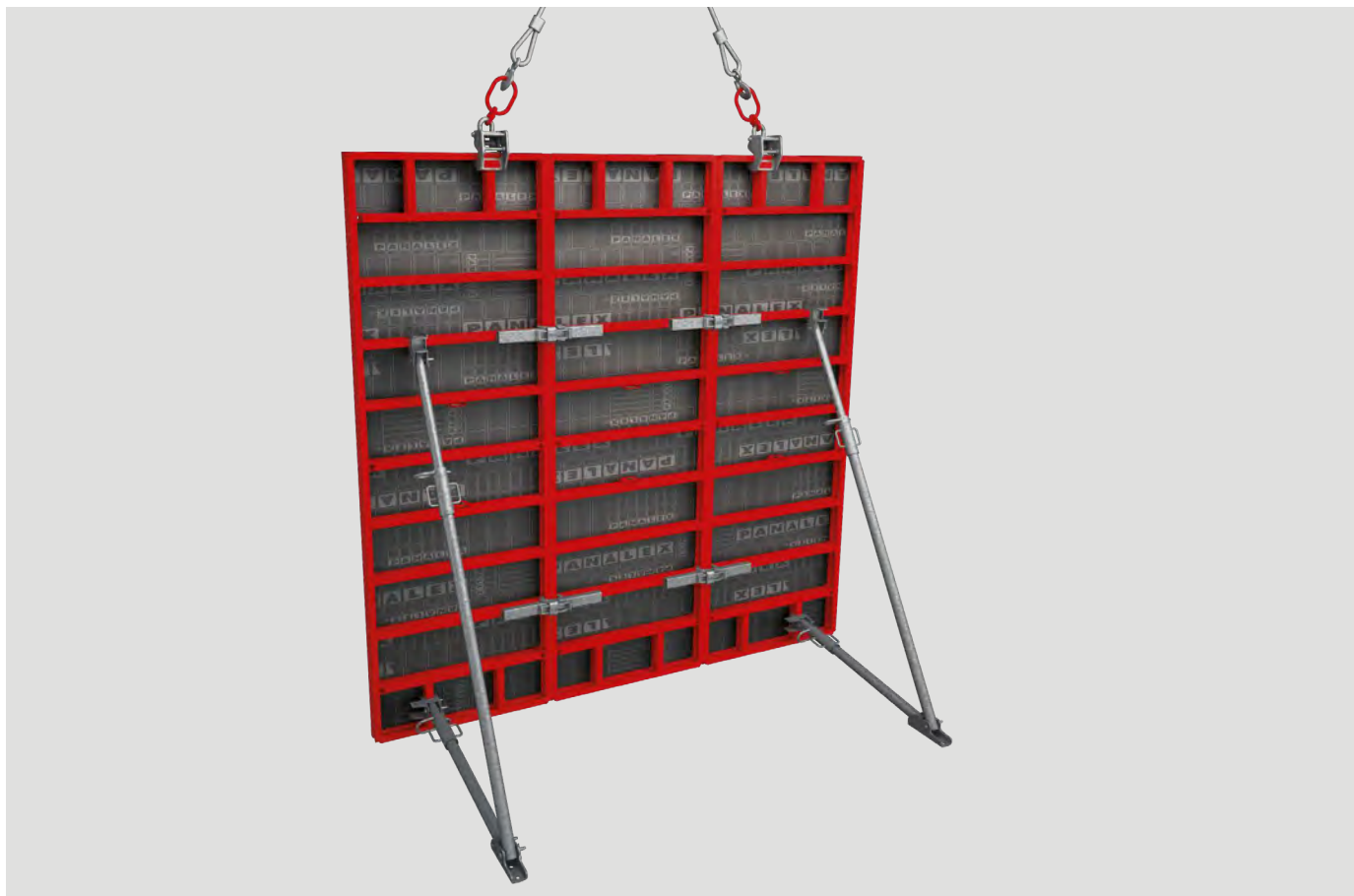

Piombatore

Le armature in cassaforma per muro vengono appoggiate contro le forze esterne orizzontali mediante puntelli e quindi disposte verticalmente. Con l'ausilio dei relativi pannelli di testa e di base, i puntelli vengono ancorati, in modo semplice e sicuro, alle casseforme e ai plinti di fondazione.

Mediante collegamenti a bullone, con o senza il relativo componente di raccordo, anche le mensole di getto standard vengono applicate in modo semplice e sicuro alle traverse del telaio.

Richtstütze

Die Wandschalung wird mittels Richtstützen gegen äußere horizontale Kräfte gehalten und ist somit senkrecht ausgerichtet. Mit Hilfe der dazugehörigen Kopf- und Fußplatten werden die Stützen an Schalungen bzw. Fundamentplatten einfach und sicher verankert.

Normgerechte Betonierkonsolen werden mittels Bolzenverbindung mit oder ohne dazugehörigem Anschlussstück an die Rahmensprossen einfach und sicher angebracht.

Stabilizer

The wall formwork is held in place against external horizontal forces by means of stabilisers and is thus aligned vertically. Using the appropriate top plates and baseplates, the formwork stabilisers or the foundation plates are simply and safely anchored.

Standard concrete consoles are simply and safely connected to the framework rungs by means of bolts with or without the relevant connecting unit.

Rassegna articoli

Artikelliste

Item list

Pannello Wandelement Panel

PWP 300

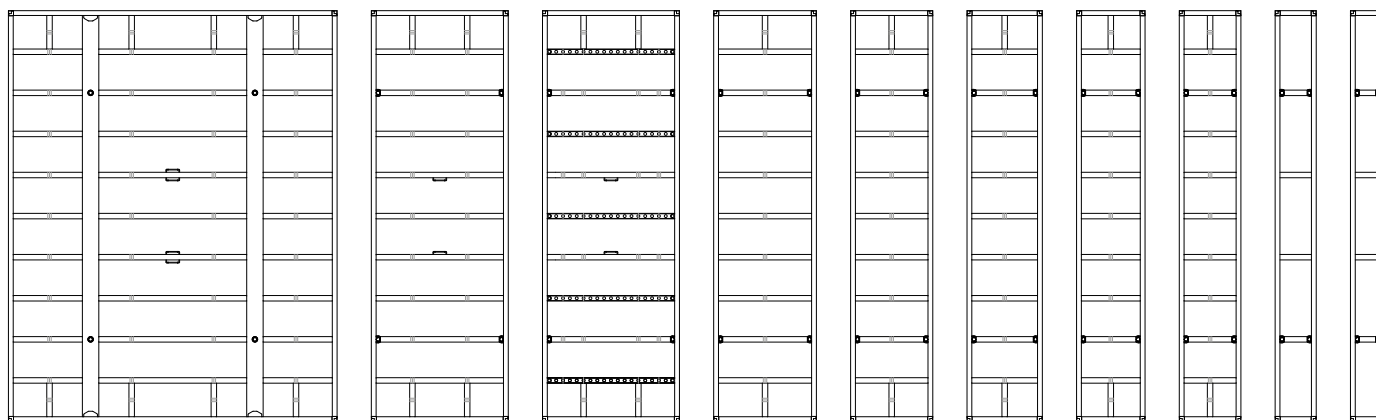

1

2

3

4

5

6

7

8

9

10

Cod. Art. Art. Nr. Code No.	Pannello Wandelement Panel	m ²	kg	Prezzo €/Pezzo Preis €/Stück Price €/Pcs.
1 PWP300X240P00	300/240	7,20	396,00	
2 PWP300X100P00	300/100	3,00	157,00	
3 PWP300X100PA0	300/100 UNI	3,00	175,00	
4 PWP300X075P00	300/75	2,25	127,00	
5 PWP300X060P00	300/60	1,80	112,00	
6 PWP300X055P00	300/55	1,65	106,00	
7 PWP300X050P00	300/50	1,50	101,00	
8 PWP300X045P00	300/45	1,35	96,00	
9 PWP300X030P00	300/30	0,90	72,00	
10 PWP300X025P00	300/25	0,75	68,00	

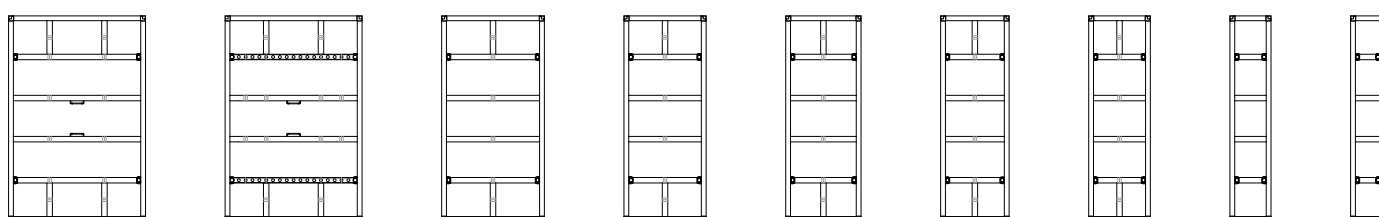
Pannello Wandelement Panel
PWP 150
**1****2****3****4****5****6****7****8****9**

Cod. Art. Art. Nr. Code No.	Pannello Wandelement Panel	m ²	kg	Prezzo €/Pezzo Preis €/Stück Price €/Pcs.
1 PWP150X100P00	150/100	1,50	91,00	
2 PWP150X100PA0	150/100 UNI	1,50	91,00	
3 PWP150X075P00	150/75	1,13	72,00	
4 PWP150X060P00	150/60	0,90	63,00	
5 PWP150X055P00	150/55	0,83	60,00	
6 PWP150X050P00	150/50	0,75	57,00	
7 PWP150X045P00	150/45	0,68	54,00	
8 PWP150X030P00	150/30	0,45	43,00	
9 PWP150X025P00	150/25	0,38	39,00	

Rassegna articoli

Artikelliste

Item list

Pannello Wandelement Panel

PW 300

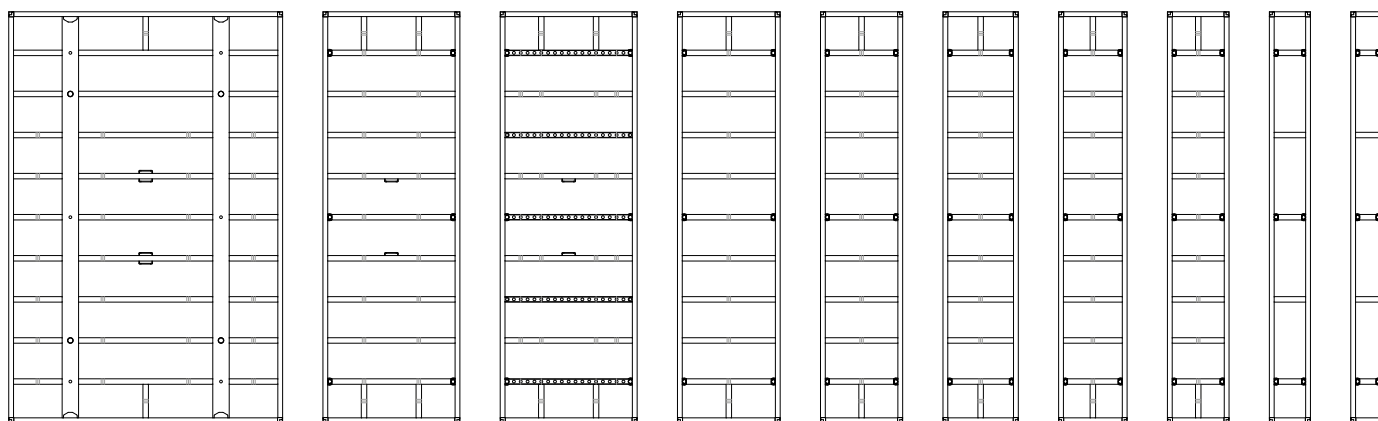

1

2

3

4

5

6

7

8

9

10

Cod. Art. Art. Nr. Code No.	Pannello Wandelement Panel	m ²	kg	Prezzo €/Pezzo Preis €/Stück Price €/Pcs.
1 PW300X200PA0	300/200-4	6,00	287,80	
2 PW300X100P00	300/100	3,00	112,00	
3 PW300X100PA0	300/100 UNI	3,00	126,00	
4 PW300X075P00	300/75	2,25	96,00	
5 PW300X060P00	300/60	1,80	82,00	
6 PW300X055P00	300/55	1,65	78,00	
7 PW300X050P00	300/50	1,50	74,00	
8 PW300X045P00	300/45	1,35	69,00	
9 PW300X030P00	300/30	0,90	51,00	
10 PW300X025P00	300/25	0,75	47,00	

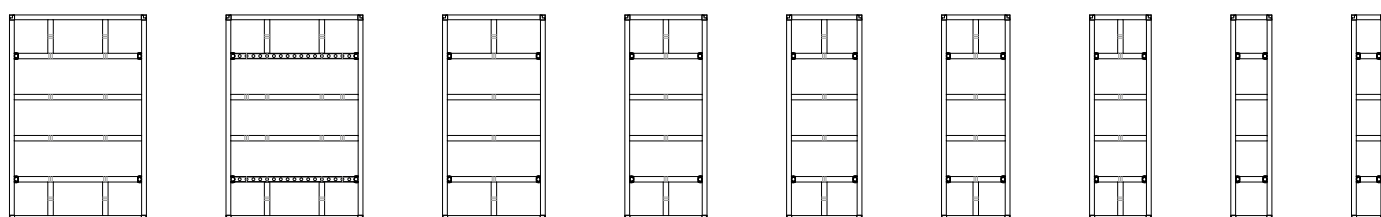
Pannello Wandelement Panel
PW 150
**1****2****3****4****5****6****7****8****9**

	Cod. Art. Art. Nr. Code No.	Pannello Wandelement Panel	m ²	kg	Prezzo €/Pezzo Preis €/Stück Price €/Pcs.
1	PW150X100P00	150/100	1,50	73,00	
2	PW150X100PA0	150/100 UNI	1,50	73,00	
3	PW150X075P00	150/75	1,13	53,00	
4	PW150X060P00	150/60	0,90	46,00	
5	PW150X055P00	150/55	0,83	43,00	
6	PW150X050P00	150/50	0,75	41,00	
7	PW150X045P00	150/45	0,68	38,00	
8	PW150X030P00	150/30	0,45	30,00	
9	PW150X025P00	150/25	0,38	27,00	

Rassegna articoli

Artikelliste

Item list

Angoli-Compensi Ecken-Ausgleiche Corner-Compensations

PWP 300

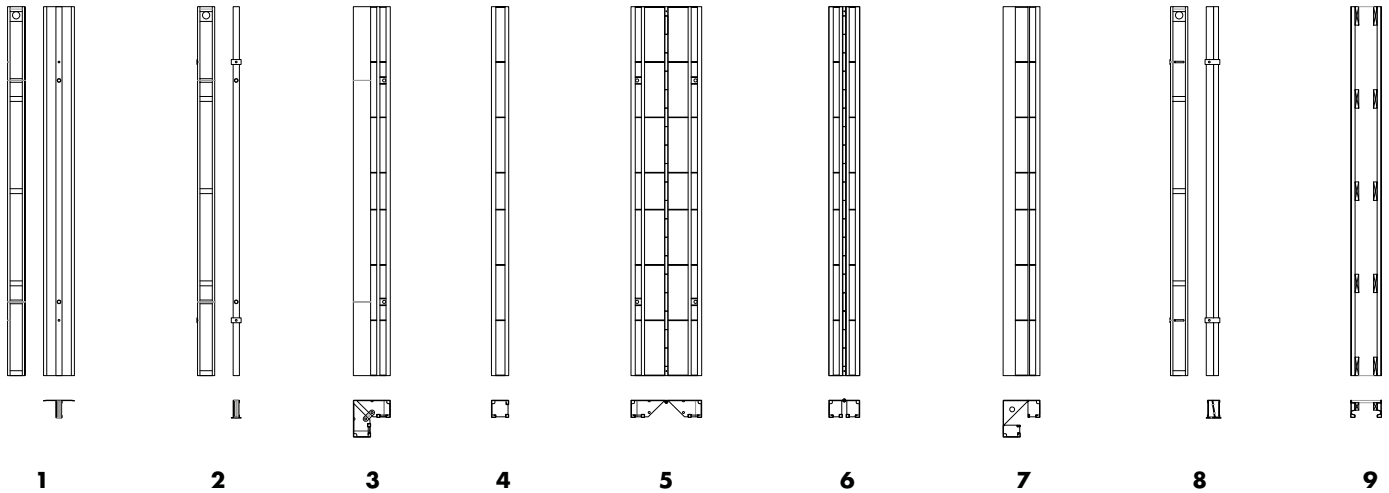

Cod. Art. Art. Nr. Code No.	Pannello Wandelement Panel				cm	m ²	kg	Prezzo €/Pezzo Preis €/Stück Price €/Pcs.
1 PWP300LC25P00	Lamiera di compenso	Ausgleichsblech	Filler plate	300/25	0,75	37,60		
2 PWP300AC05P00	Asta di compenso	Ausgleichsstab	Filler profile	300/05	0,18	20,20		
3 PWP300AI30P00	Angolo interno	Innenecke	Inner corner	300/30	1,80	99,13		
4 PWP300AE00P00	Angolo esterno	Aussenecke	Outer corner	300	0,00	35,90		
5 PWP300AS30P00	Cerniera interna	Gelenkecke innen	Inner hinge corner	300/30	1,80	94,50		
6 PWP300AS00P00	Cerniera esterna	Gelenkecke außen	Outer hinge corner	300	0,75	62,10		
7 PWP300AD30P00	Angolo conico	Ausschalecke	Striking corner	300/30	1,80	156,58		
8 PWP300PD10P00	Asta conica	Ausschalprofil	Striking profile	300/10	0,30	39,50		
9 PWP300PC00P00	Profilo vario	Ausgleichsprofil	Profile vario	300	0,00	43,33		

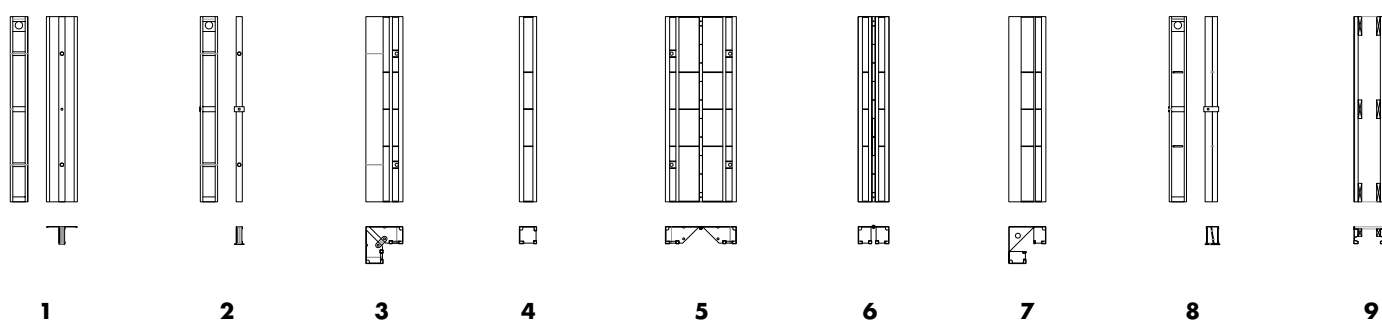
Angoli-Compensi Ecken-Ausgleiche Corner-Compensations
PWP 150

Cod. Art. Art. Nr. Code No.	Pannello Wandelement Panel			cm	m ²	kg	Prezzo €/Pezzo Preis €/Stück Price €/Pcs.
1 PWP150LC25P00	Lamiera di compenso	Ausgleichsblech	Filler plate	150/25	0,375	19,30	
2 PWP150AC05P00	Asta di compenso	Ausgleichsstab	Filler profile	150/05	0,075	10,60	
3 PWP150AI30P00	Angolo interno	Innenecke	Inner corner	150/30	0,90	48,50	
4 PWP150AE00P00	Angolo esterno	Aussenecke	Outer corner	150	0,00	18,60	
5 PWP150AS30P00	Cerniera interna	Gelenkecke innen	Inner hinge corner	150/30	0,90	49,20	
6 PWP150AS00P00	Cerniera esterna	Gelenkecke außen	Outer hinge corner	150	0,375	32,00	
7 PWP150AD30P00	Angolo conico	Ausschalecke	Striking corner	150/30	0,90	86,06	
8 PWP150PD10P00	Asta conica	Ausschalprofil	Striking profile	150/10	0,15	20,00	
9 PWP150PC00P00	Profilo vario	Ausgleichsprofil	Profile vario	150	0,00	21,68	

Rassegna articoli

Artikelliste

Item list

Angoli-Compensi Ecken-Ausgleiche Corner-Compensations

PW 300

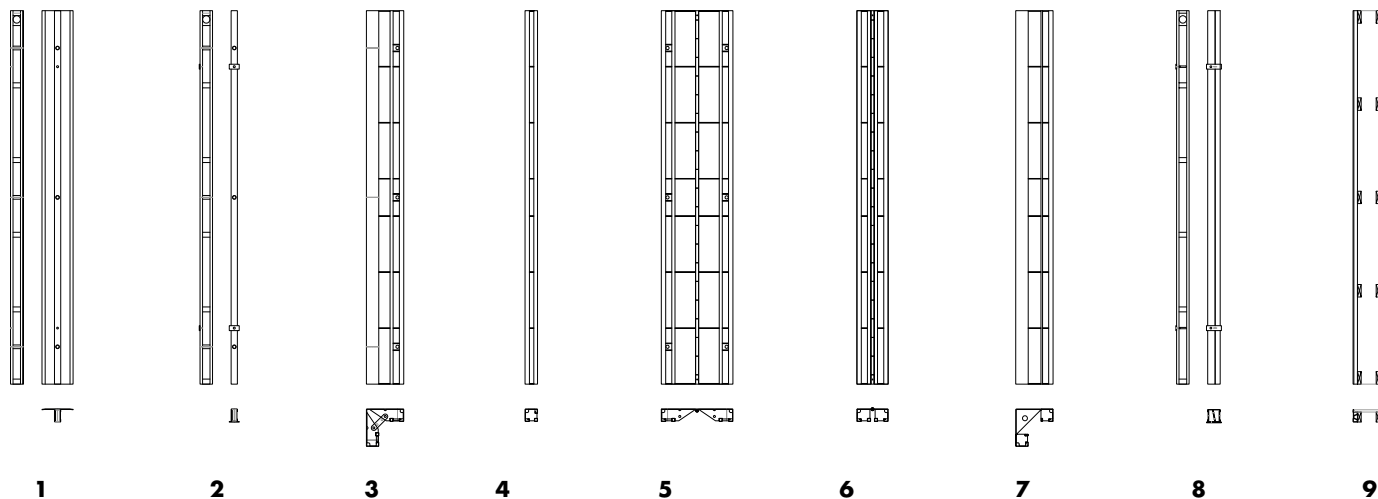

	Cod. Art. Art. Nr. Code No.	Pannello Wandelement Panel	Prezzo €/Pezzo		
			cm	m ²	kg
1	PW300LC25P00	Lamiera di compenso Ausgleichsblech Filler plate	300/25	0,75	34,50
2	PW300AC05P00	Asta di compenso Ausgleichsstab Filler profile	300/05	0,15	17,00
3	PW300AI30P00	Angolo interno Innenecke Inner corner	300/30	1,80	88,79
4	PW300AE00P00	Angolo esterno Aussenecke Outer corner	300	0,00	28,37
5	PW300AS30P00	Cerniera interna Gelenkecke innen Inner hinge corner	300/30	1,80	85,50
6	PW300AS00P00	Cerniera esterna Gelenkecke außen Outer hinge corner	300	0,75	58,27
7	PW300AD30P00	Angolo conico Ausschalecke Striking corner	300/30	1,80	147,22
8	PW300PD10P00	Asta conica Ausschalprofil Striking profile	300/10	0,30	33,00
9	PW300PC00P00	Profilo vario Ausgleichsprofil Profile vario	300	0,00	29,82

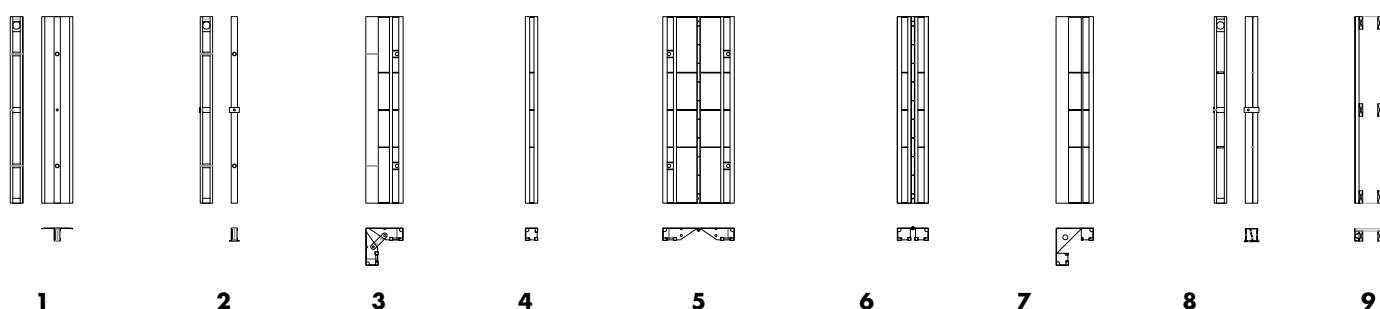
Angoli-Compensi Ecken-Ausgleiche Corner-Compensations
PW 150

	Cod. Art. Art. Nr. Code No.	Pannello Wandelement Panel				Prezzo €/Pezzo Preis €/Stück Price €/Pcs.		
			cm	m ²	kg			
1	PW150LC25P00	Lamiera di compenso	Ausgleichsblech	Filler plate	150/25	0,375	17,50	
2	PW150AC05P00	Asta di compenso	Ausgleichsstab	Filler profile	150/05	0,075	9,00	
3	PW150AI30P00	Angolo interno	Innenecke	Inner corner	150/30	0,90	45,37	
4	PW150AE00P00	Angolo esterno	Außenecke	Outer corner	150	0,00	14,44	
5	PW150AS30P00	Cerniera interna	Gelenkecke innen	Inner hinge corner	150/30	0,90	44,00	
6	PW150AS00P00	Cerniera esterna	Gelenkecke außen	Outer hinge corner	150	0,375	29,77	
7	PW150AD30P00	Angolo conico	Ausschalecke	Striking corner	150/30	0,90	80,54	
8	PW150PD10P00	Asta conica	Ausschalprofil	Striking profile	150/10	0,15	17,00	
9	PW150PC00P00	Profilo vario	Ausgleichsprofil	Profile vario	150	0,00	14,91	

Rassegna articoli

Artikelliste

Item list

Accessori di collegamento Verbindungszubehör Connecting parts

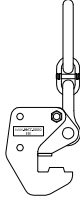

Gancio di sollevamento PW CE
Kranhaken PW CE
Lifting hook PW CE

Cod. Art. Art. – Nr. Code No.	kg/pz kg/Stk. kg/Pcs	Prezzo €/Pezzo Preis €/Stück Price €/Pcs.
PWGSCE000Z00	9,00	

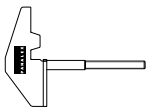

Graffa pilastro PWP
Pfeilerkralle PWP
C-Connector PWP

	Cod. Art. Art. – Nr. Code No.	kg/pz kg/Stk. kg/Pcs	Prezzo €/Pezzo Preis €/Stück Price €/Pcs.
PWP	PWPGP00000Z00	2,27	
PW	PWGP00000Z00	2,20	

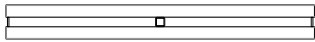

Allineatore
Riegel
Waler

	Cod. Art. Art. – Nr. Code No.	kg/pz kg/Stk. kg/Pcs	Prezzo €/Pezzo Preis €/Stück Price €/Pcs.
50	PW00AL50000Z00	4,52	
100	PW00AL10000Z00	8,77	

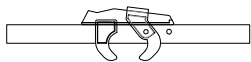

Morsa serraggio
Richtschiess
Clamp

	Cod. Art. Art. – Nr. Code No.	kg/pz kg/Stk. kg/Pcs	Prezzo €/Pezzo Preis €/Stück Price €/Pcs.
PXP	PW00MSPXP00Z00	5,80	
PX	PW00MSPX000Z00	5,00	



Morsa serraggio
Richtschiess
Clamp

	Cod. Art. Art. – Nr. Code No.	kg/pz kg/Stk. kg/Pcs	Prezzo €/Pezzo Preis €/Stück Price €/Pcs.
PXS	PW00MSPXS00Z00	3,10	

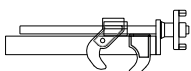

Morsa compenso
Schraubschloss
Vario clamp

	Cod. Art. Art. – Nr. Code No.	kg/pz kg/Stk. kg/Pcs	Prezzo €/Pezzo Preis €/Stück Price €/Pcs.
PX15	PW00MC15000Z00	4,80	

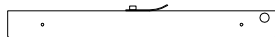
Accessori di collegamento Verbindungszubehör Connecting parts

Traversa sopralzo 50
Aufstockschiene 50
Extention bracket 50

Cod. Art. Art. – Nr. Code No.	kg/pz kg/Stk. kg/Pcs	Prezzo €/Pezzo Preis €/Stück Price €/Pcs.
PW00TS50000Z01	3,00	



Graffa tirante 60
Abspannschuh 60
End coupler 60

Cod. Art. Art. – Nr. Code No.	kg/pz kg/Stk. kg/Pcs	Prezzo €/Pezzo Preis €/Stück Price €/Pcs.
PW00GT60000Z00	1,65	



Graffa ancoraggio
Spannerkralle
Tie rod holder

Cod. Art. Art. – Nr. Code No.	kg/pz kg/Stk. kg/Pcs	Prezzo €/Pezzo Preis €/Stück Price €/Pcs.
PW00GA00000Z00	1,13	



Piastra snodata tirante DW15
Gelenkplatte DW15
Wingnut plate DW15

Cod. Art. Art. – Nr. Code No.	kg/pz kg/Stk. kg/Pcs	Prezzo €/Pezzo Preis €/Stück Price €/Pcs.
PW00DW15PSTZ01	2,00	



Tirante DW15 L = 100 cm
Spannstab DW15 L = 100 cm
Tie rod DW15 L = 100 cm

Cod. Art. Art. – Nr. Code No.	kg/pz kg/Stk. kg/Pcs	Prezzo €/Pezzo Preis €/Stück Price €/Pcs.
FECEB1S100N	1,44	

Rassegna articoli

Artikelliste

Item list

Sicurezza e trasporto Sicherheit und Transport Safety and transport

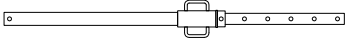
	Piombatore Richtstütze Stabilizer	Cod. Art.	kg/pz	Prezzo €/Pezzo
		Art. – Nr. Code No.	kg/Stk. kg/Pcs	Preis €/Stück Price €/Pcs.
		150 PFOOPT15000Z00	6,00	
		300 PFOOPT30000Z00	9,60	
		450 PFOOPT45000Z00	12,28	
		600 PFOOPT60000Z00	33,50	

	Testa piombatore Anschluss-Richtstütze Connector stabilizer	Cod. Art.	kg/pz	Prezzo €/Pezzo
		Art. – Nr. Code No.	kg/Stk. kg/Pcs	Preis €/Stück Price €/Pcs.
		PW00TPT0000Z00	1,75	

	Basetta piombatore Fussplatte Richtstütze Base plate stabilizer	Cod. Art.	kg/pz	Prezzo €/Pezzo
		Art. – Nr. Code No.	kg/Stk. kg/Pcs	Preis €/Stück Price €/Pcs.
		PW00BPT0000Z00	2,70	

	Perno 16/110 Bolzen 16/110 Pin 16/110	Cod. Art.	kg/pz	Prezzo €/Pezzo
		Art. – Nr. Code No.	kg/Stk. kg/Pcs	Preis €/Stück Price €/Pcs.
		PXP16X110Z	0,17	

	Copiglia R D-3.5 Federstecker R D-3.5 Safety R clip D-3.5	Cod. Art.	kg/pz	Prezzo €/Pezzo
		Art. – Nr. Code No.	kg/Stk. kg/Pcs	Preis €/Stück Price €/Pcs.
		PXCPR3.5Z	0,01	

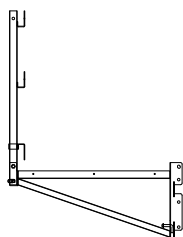
Sicurezza e trasporto Sicherheit und Transport Safety and transport

Mensola di servizio 90 UNI
 Betonierkonsole 90 UNI
 Walkway bracket 90 UNI

incl. 2 perni e 2 copiglie
 inkl. 2 Bolzen und 2 Federstecker
 encl. 2 pin and 2 safety pin

Cod. Art. Art. – Nr. Code No.	kg/pz kg/Stk. kg/Pcs	Prezzo €/Pezzo Preis €/Stück Price €/Pcs.
PW00MS90000Z01	12,50	

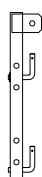

Attacco mensola di servizio
 Anschluss Betonierkonsole
 Connector walkway bracket

Cod. Art. Art. – Nr. Code No.	kg/pz kg/Stk. kg/Pcs	Prezzo €/Pezzo Preis €/Stück Price €/Pcs.
PW00AMS0000Z00	2,75	



Montante trasporto pannelli
 Transportwinkel
 Transport bracket

	Cod. Art. Art. – Nr. Code No.	kg/pz kg/Stk. kg/Pcs	Prezzo €/Pezzo Preis €/Stück Price €/Pcs.
4/6	PW00MT08000Z00	7,25	
6/8	PW00MT10000Z00	8,70	
7/10	PW00MT12000Z00	9,56	

Tappo per boccola
 Stopfen für Hülse
 Plug bocal

Cod. Art. Art. – Nr. Code No.	kg/pz kg/Stk. kg/Pcs	Prezzo €/Pezzo Preis €/Stück Price €/Pcs.
PF60012V00	0,003	

Tappo in PVC
 Stopfen in PVC
 Plug in PVC

Cod. Art. Art. – Nr. Code No.	kg/pz kg/Stk. kg/Pcs	Prezzo €/Pezzo Preis €/Stück Price €/Pcs.
PVCTAP24	0,0049	

Sistema Casseforme Systemschalung Concrete formwork system



PANAWALL
Cassero a telaio
Rahmenschalung
Framed formwork



PANADECK
Cassaforma per solaio
Deckenschalung
Slab formwork



PANAWALL Round
Cassaforma per parete
Rundes Systemschalung
Round Formwork system



TMF Puntellazione monofaccia
TMF Abstützbock für einhäuptige
Schalung
TMF Single side support frame

Accessori per casseforme Schalungszubehör Formwork accessories



Distanziatori & Accessori
Abstandhalter & Zusatzteile
Spacers & fittings



Sistemi d'armatura
Bewehrungssysteme
Reinforcement systems



Impermeabilizzazioni
Bauwerksabdichtungen
Structural waterproofing



Sistemi di cassatura
Schalungstechnik
Formwork accessories



Morsetti
Schalungsklemmen
Formwork clamps



Barre e accessori
Schalungsanker & Zubehör
Formwork anchor & accessories



Giunti
Kupplung
Coupling

Prodotti in legno Holzprodukte Timber products



Multistrato filmato
Sperrholz befilmt
Filmfaced plywood

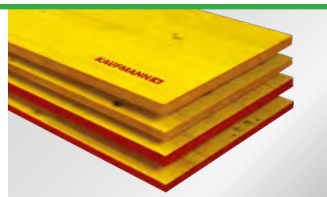

Pannelli per casseforme
Holzschalungsplatten
Shuttering panels



Travi per casseforme
Holzschalungsträger
Concrete formwork beams

Servizio Service Service



Noleggio casseforme & progettazione
Schalungsmiete & Planung
Formwork rental & planning



Logistica
Logistik
Logistics



Ripristino casseforme
Schalungsrenovierung
Formwork renewal



Lavorazione pannelli
Plattenzuschnitt
Machined panels

Siamo vicinissimi a voi

Abbiamo un rapporto stretto e speciale con i nostri clienti. Questo perché li conosciamo e sappiamo non solo quanto sia duro il loro lavoro, ma anche quanto è spietata la loro concorrenza. Il nostro punto di partenza è la realtà: ci sprona a trasformare i problemi in soluzioni per offrire la massima sicurezza possibile con un elevatissimo livello di efficienza. Va da sé che anche le nostre sedi sono state scelte in modo da soddisfare ampiamente le esigenze dei nostri clienti.

Wir sind Ihnen ganz nah

Zu unseren Kunden haben wir ein besonderes Nahverhältnis. Das liegt daran, dass wir unsere Kunden, ihren harten Job und ihren ebenso harten Wettbewerb kennen. Für uns ist diese Realität die Voraussetzung, um Probleme in Lösungen umzusetzen, um grösstmögliche Sicherheit bei maximaler Effizienz anzubieten. Naheliegend, dass auch unsere Standorte so ausgewählt wurden, dass sie unseren Kunden ein grosses Stück entgegenkommen.

We are nearby

We have a special relationship with our customers, because we know them, the hard nature of their work and the equally tough competition out there. For us, reality is the requirement in implementing solutions to problems and offering maximum safety with maximum efficiency. So it goes without saying that our locations have been chosen with proximity to our customers in mind.

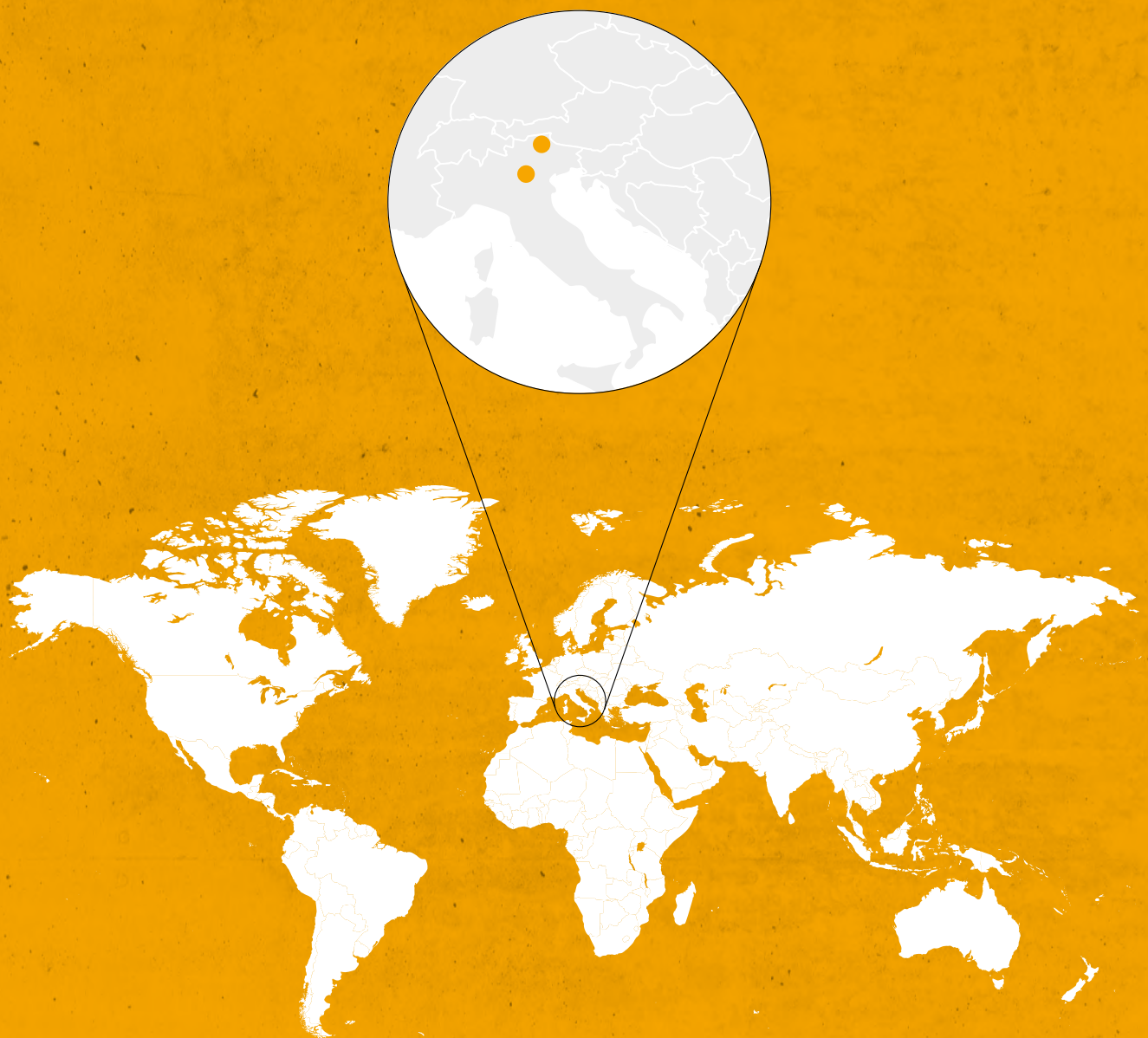

Sede e smistamento
Firmensitz & Lager
HQ and warehouse
PANALEX GmbH
Industriezone 16
I-39030 Olang/BZ
T +39 0474 49 50 00
E info@panalex.it



Centro di smistamento
Auslieferungslager
Distribution centre
PANALEX Srl
Zona Industriale
Via Tasso 20
I-37010 Albarè di
Costermano/VR

Sede centrale | Hauptsitz | Headquarter

PANALEX GmbH

Industriezone 16

I-39030 Olang/BZ/Italy

T+39 0474 49 50 00

info@panalex.it, www.panalex.it

Logistica | Logistik | Logistics

Produzione | Produktion | Production

I-39030 Olang/BZ

I-37010 Albaré di

Costermano/VR

AspettateVi da parte nostra una collaborazione costruttiva e soluzioni produttive.

Erwarten Sie von uns konstruktive Zusammenarbeit und produktive Lösungen.

You can expect from us constructive cooperation and productive solutions.

■ **Sistema Casseforme**
Systemschalung
Concrete formwork system

■ **Accessori per casseforme**
Schalungszubehör
Formwork accessories

■ **Prodotti in legno**
Holzprodukte
Timber products

■ **Servizio**
Service
Service